

Permanent Magnet DC Machine

FESTO

Electricity and New Energy

LabVolt Series

Student Manual

FESTO



Student Manual

Permanent Magnet DC Machine

Germany

Festo Didactic SE
Rechbergstr. 3
73770 Denkendorf
Tel.: +49 711 3467-0
Fax: +49 711 347-54-88500
did@festo.com

United States

Festo Didactic Inc.
607 Industrial Way West
Eatontown, NJ 07724
Tel.: +1 732 938-2000
Toll Free: +1-800-522-8658
Fax: +1 732 774-8573
services.didactic@festo.com

Canada

Festo Didactic Ltée/Ltd
675, rue du Carbone
Québec (Québec) G2N 2K7
Tel.: +1 418 849-1000
Toll Free: +1-800-522-8658
Fax: +1 418 849-1666
services.didactic@festo.com

www.festo-didactic.com



000057936200000000000100

Festo Didactic
en
579362

Electricity and New Energy

Permanent Magnet DC Motor

Student Manual

579362

Order no.: 579362
Revision level: 12/2014

By the staff of Festo Didactic

© Festo Didactic Ltée/Ltd, Quebec, Canada 2011
Internet: www.festo-didactic.com
e-mail: did@de.festo.com

Printed in Canada
All rights reserved

ISBN 978-2-89640-504-6 (Printed version)

ISBN 978-2-89747-238-2 (CD-ROM)

Legal Deposit – Bibliothèque et Archives nationales du Québec, 2011

Legal Deposit – Library and Archives Canada, 2011

The purchaser shall receive a single right of use which is non-exclusive, non-time-limited and limited geographically to use at the purchaser's site/location as follows.

The purchaser shall be entitled to use the work to train his/her staff at the purchaser's site/location and shall also be entitled to use parts of the copyright material as the basis for the production of his/her own training documentation for the training of his/her staff at the purchaser's site/location with acknowledgement of source and to make copies for this purpose. In the case of schools/technical colleges, training centers, and universities, the right of use shall also include use by school and college students and trainees at the purchaser's site/location for teaching purposes.

The right of use shall in all cases exclude the right to publish the copyright material or to make this available for use on intranet, Internet and LMS platforms and databases such as Moodle, which allow access by a wide variety of users, including those outside of the purchaser's site/location.

Entitlement to other rights relating to reproductions, copies, adaptations, translations, microfilming and transfer to and storage and processing in electronic systems, no matter whether in whole or in part, shall require the prior consent of Festo Didactic GmbH & Co. KG.

















Information in this document is subject to change without notice and does not represent a commitment on the part of Festo Didactic. The Festo materials described in this document are furnished under a license agreement or a nondisclosure agreement.

Festo Didactic recognizes product names as trademarks or registered trademarks of their respective holders.

All other trademarks are the property of their respective owners. Other trademarks and trade names may be used in this document to refer to either the entity claiming the marks and names or their products. Festo Didactic disclaims any proprietary interest in trademarks and trade names other than its own.

Safety and Common Symbols

The following safety and common symbols may be used in this manual and on the equipment:

Symbol	Description
	DANGER indicates a hazard with a high level of risk which, if not avoided, will result in death or serious injury.
	WARNING indicates a hazard with a medium level of risk which, if not avoided, could result in death or serious injury.
	CAUTION indicates a hazard with a low level of risk which, if not avoided, could result in minor or moderate injury.
	CAUTION used without the <i>Caution, risk of danger</i> sign  , indicates a hazard with a potentially hazardous situation which, if not avoided, may result in property damage.
	Caution, risk of electric shock
	Caution, hot surface
	Caution, risk of danger
	Caution, lifting hazard
	Caution, hand entanglement hazard
	Notice, non-ionizing radiation
	Direct current
	Alternating current
	Both direct and alternating current
	Three-phase alternating current
	Earth (ground) terminal

Safety and Common Symbols









Symbol	Description
	Protective conductor terminal
	Frame or chassis terminal
	Equipotentiality
	On (supply)
	Off (supply)
	Equipment protected throughout by double insulation or reinforced insulation
	In position of a bi-stable push control
	Out position of a bi-stable push control

Table of Contents

Preface	VII
About This Manual	IX
Introduction Permanent Magnet DC Motors	1
DISCUSSION OF FUNDAMENTALS	1
Work, torque, and power.....	1
Basic dc motor operation	3
Permanent magnet dc motors.....	5
Exercise 1 Prime Mover and Brake Operation	7
DISCUSSION	7
Introduction to the Four-Quadrant Dynamometer/Power Supply	7
Two-quadrant constant-torque brake.....	7
Clockwise constant-speed prime mover/brake	8
Counterclockwise constant-speed prime mover/brake	9
Speed, torque, and mechanical power measurements using the Four-Quadrant Dynamometer/Power Supply.....	10
Motor operation	10
Generator operation	10
PROCEDURE.....	11
Setup and connections	11
Two-quadrant, constant-torque brake operation.....	13
Constant-speed prime mover operation	16
Constant-speed prime mover driving a loaded generator	19
Exercise 2 Permanent Magnet DC Motor Operating as a Generator.....	25
DISCUSSION	25
Permanent magnets.....	25
Magnetic field around a conductor.....	26
Magnetic field in a loop of wire (electromagnet)	27
Electromagnetic induction.....	29
Construction of a permanent magnet dc motor	33
Permanent magnet dc motor operating as a generator.....	34
Reducing the fluctuations of the generated dc voltage.....	38
Characteristic of the generated voltage as a function of the rotation speed	40
Torque opposing rotation in a permanent magnet dc motor operating as a generator.....	40
Opposition torque-versus-current characteristic	42

Table of Contents

PROCEDURE	43
Electromagnetic induction phenomenon	43
Opposition to rotation	44
Voltage-versus-speed characteristic of a permanent magnet dc motor operating as a generator	44
Clockwise rotation	46
Counterclockwise rotation	47
Torque-versus-current characteristic of a permanent magnet dc motor operating as a generator	48
Exercise 3 Permanent Magnet DC Motor Operating as a Motor	55
DISCUSSION	55
Operation of a permanent magnet dc motor as a motor	55
Magnetic field produced in the armature	56
Armature rotation resulting from the interaction between the magnetic fields of the armature and permanent magnets	58
Equivalent diagram of a permanent magnet dc motor	60
PROCEDURE	63
Setup and connections	64
Speed-versus-voltage characteristic of a permanent magnet dc motor operating as a motor	65
Clockwise rotation	65
Counterclockwise rotation	67
Torque-versus-current and speed-versus-torque characteristics of a permanent magnet dc motor operating as a motor	68
Clockwise rotation	68
Counterclockwise rotation	70
Appendix A Equipment Utilization Chart	75
Appendix B Glossary of New Terms	77
Appendix C Circuit Diagram Symbols	79
Appendix D Preparation of the Lead-Acid Battery Pack	85
Charging procedure	85
Sulfation test	86
Battery maintenance	87
Index of New Terms	89
Bibliography	91

Preface

The production of energy using renewable natural resources such as wind, sunlight, rain, tides, geothermal heat, etc., has gained much importance in recent years as it is an effective means of reducing greenhouse gas (GHG) emissions. The need for innovative technologies to make the grid smarter has recently emerged as a major trend, as the increase in electrical power demand observed worldwide makes it harder for the actual grid in many countries to keep up with demand. Furthermore, electric vehicles (from bicycles to cars) are developed and marketed with more and more success in many countries all over the world.

To answer the increasingly diversified needs for training in the wide field of electrical energy, the Electric Power Technology Training Program was developed as a modular study program for technical institutes, colleges, and universities. The program is shown below as a flow chart, with each box in the flow chart representing a course.

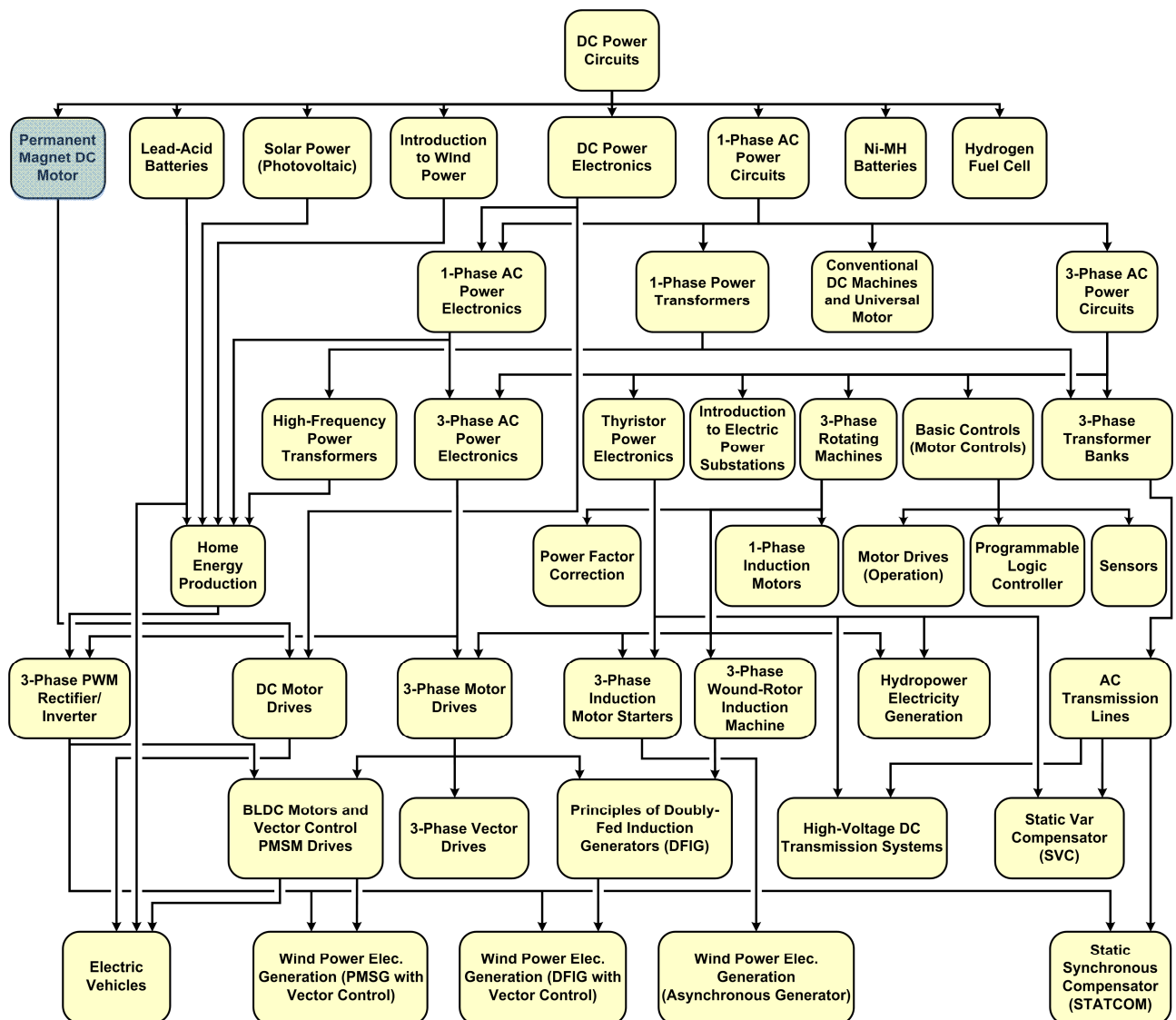

The Electric Power Technology Training Program.

Preface

The program starts with a variety of courses providing in-depth coverage of basic topics related to the field of electrical energy such as ac and dc power circuits, power transformers, rotating machines, ac power transmission lines, and power electronics. The program then builds on the knowledge gained by the student through these basic courses to provide training in more advanced subjects such as home energy production from renewable resources (wind and sunlight), large-scale electricity production from hydropower, large-scale electricity production from wind power (doubly-fed induction generator [DFIG], synchronous generator, and asynchronous generator technologies), smart-grid technologies (SVC, STATCOM, HVDC transmission, etc.), storage of electrical energy in batteries, and drive systems for small electric vehicles and cars.

Do you have suggestions or criticism regarding this manual?

If so, send us an e-mail at did@de.festo.com.

The authors and Festo Didactic look forward to your comments.

About This Manual

Rotating machines such as electrical motors and generators (or alternators) are found in almost every sector of the industry. The basic principles of operation of rotating machines have been known for almost two centuries. Rotating machines operate due to the interaction between magnetic fields and current-carrying conductors, and are split into two basic categories: motors and generators.

Permanent magnet dc motors are rotating machines that operate using direct current (i.e., they are dc powered). They can be used as either generators or motors. Permanent magnet dc motors are rugged components that are easy to connect and require little maintenance. They are found in a variety of applications, such as battery charging, small electric vehicles, windmill technology, mobility scooters, pumps, machine tools, kitchen appliances, optical equipment, etc.

The present course introduces the student to permanent magnet dc motors used as either generators or motors. The course covers the construction, operating principles, and characteristic curves of permanent magnet dc motors related to each of these two operating modes.

The equipment for the course mainly consists of the Permanent Magnet DC Motor and the Four-Quadrant Dynamometer/Power Supply. The operation of the motor is controlled using the LVDAC-EMS software, which also provides the instrumentation required to record the experimental data and plot characteristic curves.

Safety considerations

Safety symbols that may be used in this manual and on the equipment are listed in the Safety Symbols table at the beginning of the manual.

Safety procedures related to the tasks that you will be asked to perform are indicated in each exercise.

Make sure that you are wearing appropriate protective equipment when performing the tasks. You should never perform a task if you have any reason to think that a manipulation could be dangerous for you or your teammates.

Prerequisite

As a prerequisite to this course, you should have read the manual titled *DC Power Circuits*, p.n. 86350.

Systems of units

Units are expressed using the International System of Units (SI) followed by the units expressed in the U.S. customary system of units (between parentheses).

Permanent Magnet DC Motors

MANUAL OBJECTIVE

When you have completed this manual, you will be familiar with the construction and operation of permanent magnet dc motors used as either generators or motors. You will be familiar with the characteristic curves of permanent magnet dc motors related to each of these two operating modes.

DISCUSSION OUTLINE

The Discussion of Fundamentals covers the following points:

- Work, torque, and power
- Basic dc motor operation
- Permanent magnet dc motors

DISCUSSION OF FUNDAMENTALS

Work, torque, and power

The mechanical **work** W that is done when a force F moves an object over a distance d can be calculated using the following equation:

$$W = F \cdot d \quad (1)$$

where W is the mechanical work done by the force, expressed in joules (J) or in pound-force inches (lbf-in).

F is the magnitude of the force moving the object, expressed in newtons (N) or in pound-forces (lbf).

d is the distance over which the force moves the object, expressed in meters (m) or in inches (in).

Figure 1 shows the example of a block that is moved over a distance d of 1 m (39.4 in) by a force F of 1 N (0.22 lbf). Using Equation (1), it can be calculated that a mechanical work W of 1 J (8.85 lbf-in) has been done.

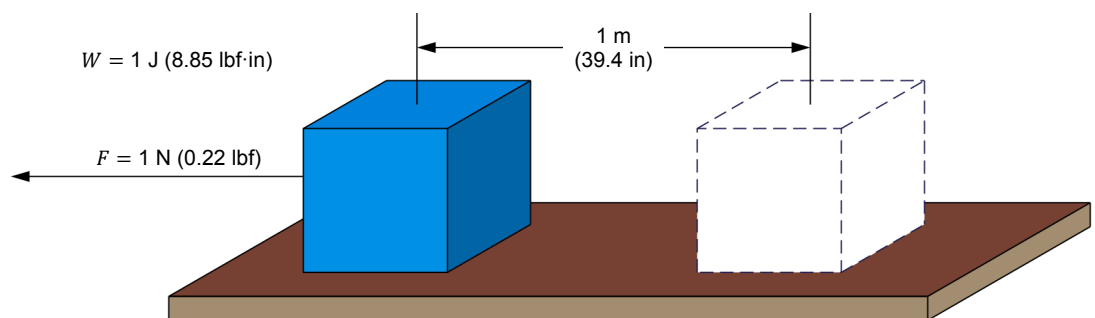

Figure 1. Work required to move a block.

Consider now that the block in Figure 1 is moved over the same distance using a pulley that has a radius r , as shown in Figure 2.

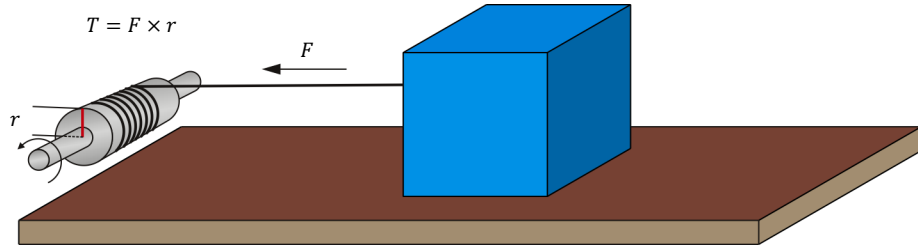

Figure 2. Moving a block using a pulley.

A twisting force must be applied on the pulley shaft to make it rotate so that the rope wound around the pulley shaft pulls the block with a force F . This twisting force is known as the **torque** T and is defined by the following equation:

$$T = F \cdot r \quad (2)$$

- where
- T is the torque exerted on the pulley shaft, expressed in newton-meters (N·m) or in pound-force inches (lbf·in).
 - F is the magnitude of the force acting on the pulley shaft, expressed in newtons (N) or in pound forces (lbf).
 - r is the radius of the pulley, expressed in meters (m) or in inches (in).

At the end of each complete rotation of the pulley, the block has been pulled a distance of $(2\pi \cdot r)$ m or in, meaning that a work of $(2\pi \cdot r \cdot F)$ J or lbf·in has been done. Since $T = F \cdot r$, the amount of work W done in one revolution can be expressed as $(2\pi \cdot T)$ J or lbf·in.

Power P is defined as the rate of doing work, and it is calculated using the following equation when work W is expressed in joules.

$$P = \frac{W}{t} \quad (3)$$

- where
- P is the power of the device doing the work, expressed in watts (W).
 - W is the amount of work done, expressed in joules (J).
 - t is the time taken to do the work, expressed in seconds (s).

When work W is expressed in pound-force inches (lbf·in), the following equation must be used to calculate the power P :

In Equation (4) and Equation (6), the term $1/8.85$ is used to convert the work W , expressed in pound-force inches (lbf·in), into a work W expressed in joules (J).

$$P = \frac{W}{t} \cdot \frac{1}{8.85} = \frac{W}{8.85 \times t} \quad (4)$$

where W is the amount of work done, expressed in pound-force inches (lbf·in).

Since power is work done per unit of time, the power P of a motor turning at a speed n can be found using the following equation when the torque T is expressed in newton-meters (N·m).

In Equation (5) and Equation (6), the term $1/60$ s is used to convert the motor speed n , expressed in revolutions per minute (r/min), into a speed n expressed in revolutions per second (r/s).

$$P = n \cdot \frac{1 \text{ min}}{60 \text{ s}} \cdot 2\pi T = n \cdot \frac{1 \text{ min}}{9.55 \text{ s}} \cdot T = \frac{n \cdot T}{9.55} \quad (5)$$

where n is the motor speed of rotation, expressed in revolutions per minute (r/min).

When torque T is expressed in pound-force inches (lbf·in), the power P of the motor can be found using the following equation:

$$P = n \cdot \frac{1 \text{ min}}{60 \text{ s}} \cdot 2\pi T \cdot \frac{1}{8.85} = n \cdot T \cdot \frac{1 \text{ min}}{84.5 \text{ s}} = \frac{n \cdot T}{84.5} \quad (6)$$

It is possible to obtain the power P , expressed in horsepower (hp), for any given power P , expressed in watts (W), by dividing the power value in watts by 746.

Basic dc motor operation

A dc motor is a rotating electromechanical machine that operates using direct current (i.e., the machine is dc powered). For instance, when a dc power source like a battery is connected to the terminals of a dc motor, the motor starts to rotate and rotational mechanical power is produced at the motor shaft, as Figure 3 shows.

The rotational mechanical power produced at the motor shaft is available to make an object rotate. This object can be the bladed rotor of a fan, the driving wheels of a vehicle, etc. Electrical energy from the battery is thus converted into mechanical (rotational) energy by the dc motor.

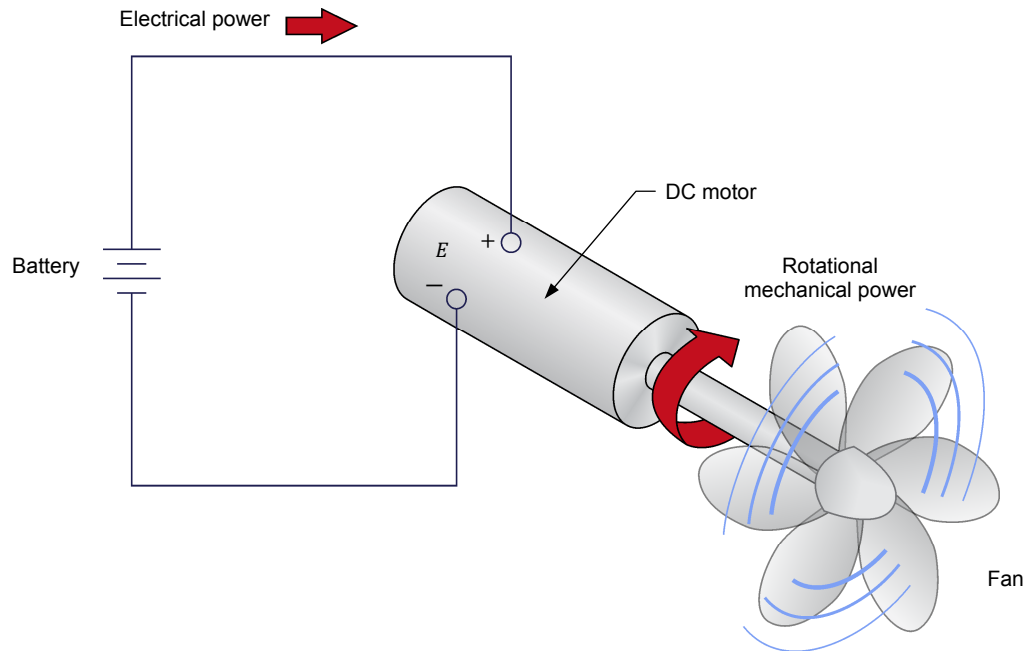

Figure 3. Operation as a motor: the dc motor converts electrical power into rotational mechanical power that makes the fan turn.

A dc motor can also perform the opposite action, i.e., convert rotational mechanical power into electrical power, as Figure 4 shows. When rotational mechanical power is applied to the shaft of the dc motor, the shaft starts to rotate and dc voltage appears at the motor terminals. When an electric load is connected to the motor terminals, current flows through the load and electrical power is consumed by the load. In this case, the dc motor operates as a generator since it produces electrical energy from the mechanical energy applied to its shaft (instead of converting electrical energy applied to its terminals into mechanical energy).

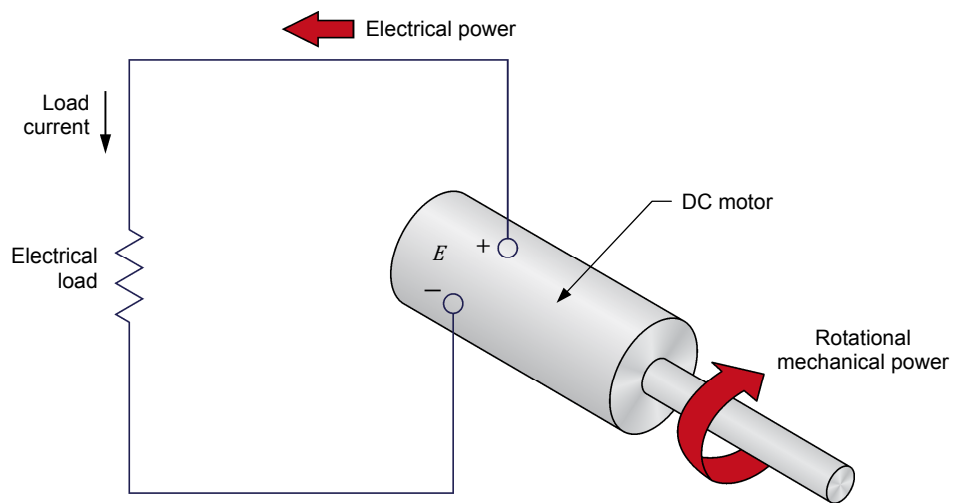

Figure 4. Operation as a generator: the dc motor converts rotational mechanical power into electrical power that is consumed by an electric load.

Permanent magnet dc motors

Permanent magnet dc motors use the magnetic field produced by permanent magnets to operate. Permanent magnet dc motors commonly found on the market operate in the power range of a few watts (W) up to tens of kilowatts (kW). Small permanent magnet dc motors are rated for input dc voltages of 5 V, 12 V, 24 V, 48 V.

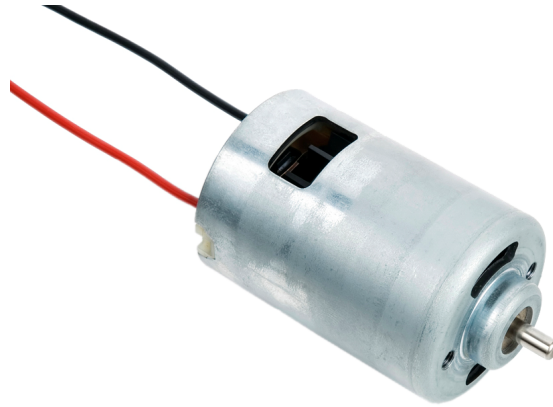

Figure 5. Small permanent magnet dc motor.

Industrial motors are rated for dc voltages of 90 to 180 V and, in larger applications, for voltages of 250 V and sometimes higher.

Permanent magnet dc motors are rugged electrical components. They are easy to connect because they are powered using two electrical wires only. Furthermore, they require little maintenance since they have very few parts subjected to wear. The parts that are subjected to wear are carbon fiber **brushes**. These brushes wear out with motor usage. They must therefore be replaced occasionally. The brush replacement interval depends on motor usage.

Permanent magnet dc motors generally have a good power efficiency since no electrical power is lost in producing the magnetic field (this magnetic field is naturally produced by a **permanent magnet**) necessary for its operation. This makes permanent magnet dc motors a serious option in any application where power efficiency is at a premium.

Permanent magnet dc motors are used in many applications, including small electric vehicles, windmill technology, mobility scooters, golf cars, kitchen appliances, lawn and garden equipment, machine tools, forklifts, optical equipment, robots, pump drives, blower drives, marine pumps, reels and winches, railroad equipment, etc.



Figure 6. Permanent magnet dc motors can be used to power electric bicycles and scooters.



Figure 7. Permanent magnet dc motors can be used in mobility scooters and golf carts.

Prime Mover and Brake Operation

EXERCISE OBJECTIVE

When you have completed this exercise, you will be familiar with the basic functions of the Four-Quadrant Dynamometer/Power Supply used in this manual. You will also be familiar with the polarity of the speed, torque, and mechanical power for a machine operating as either a motor or a generator.



The hands-on exercises in this manual require you to be familiar with the computer-based instruments in this training system. Refer to user guides Data Acquisition and Control System, Model 86716-E, and Computer-Based Instruments for EMS, Model 86718-E, to become familiar with the operation and use of these computer-based instruments.

DISCUSSION OUTLINE

The Discussion of this exercise covers the following points:

- Introduction to the Four-Quadrant Dynamometer/Power Supply
 - Two-quadrant constant-torque brake
 - Clockwise constant-speed prime mover/brake
 - Counterclockwise constant-speed prime mover/brake
- Speed, torque, and mechanical power measurements using the Four-Quadrant Dynamometer/Power Supply
 - Motor operation
 - Generator operation

DISCUSSION

Introduction to the Four-Quadrant Dynamometer/Power Supply

The Four-Quadrant Dynamometer/Power Supply module used in this manual consists of complex power electronics circuits, a microcontroller, and a dc motor. The module can be used to implement a multitude of functions. All mechanical functions (i.e., all functions using the dc motor) enable the Four-Quadrant Dynamometer/Power Supply module to act as a **dynamometer**, i.e., to measure the torque created by the machine connected to it. The following three basic functions are described in this exercise:

1. Two-quadrant constant-torque brake
2. Clockwise constant-speed **prime mover**/brake
3. Counterclockwise constant-speed prime mover/brake

These three functions are explained in more details below.

Two-quadrant constant-torque brake

This function is used to study rotating machines operating as motors (i.e., converting electrical energy into mechanical energy). The two-quadrant

constant-torque brake can be used to mechanically load a motor (i.e., to create an opposition torque acting against the torque produced by the motor to rotate), as Figure 8 shows. It is thus possible to study the speed, torque, and mechanical power of the motor under test as load torque is applied to it.

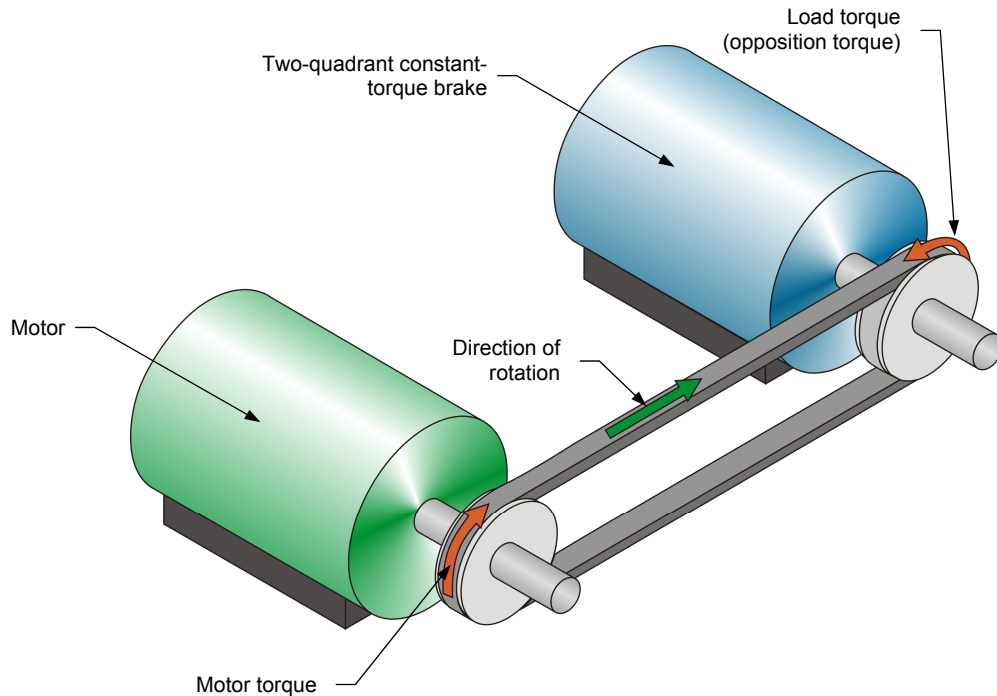

Figure 8. Motor coupled to a two-quadrant constant-torque brake.

When the Four-Quadrant Dynamometer/Power Supply is operating as a two-quadrant, constant-torque brake, it is possible to set the magnitude of the load torque produced by the brake. The Four-Quadrant Dynamometer/Power Supply window in the LVDAC-EMS software has speed, torque, power, and energy meters that indicate the different parameters measured for the machine under test. For example, the torque indicated by the torque meter corresponds to the torque produced by the motor under test, not the load torque produced by the two-quadrant, constant-torque brake.

When determining the torque produced by the motor to which it is coupled, the Four-Quadrant Dynamometer/Power Supply automatically compensates for its own friction torque and for the belt friction torque. Thus, the torque indicated by the torque meter in the Four-Quadrant Dynamometer/Power Supply window of the LVDAC-EMS software represents the actual torque produced at the shaft of the motor under test. Similarly, the mechanical power indicated by the power meter in the Four-Quadrant Dynamometer/Power Supply window represents the corrected mechanical power at the shaft of the motor under test.

Clockwise constant-speed prime mover/brake

This control function is used mainly to study rotating machines operating as generators (i.e., converting mechanical energy into electrical energy). The clockwise constant-speed prime mover/brake can be used to drive a rotating machine (i.e., to make the machine rotate with the prime mover/brake), as Figure 9 shows. In this case, the Four-Quadrant Dynamometer/Power Supply

operates as a prime mover. Since the clockwise constant-speed prime mover/brake can operate in two quadrants, it can also be used to reduce the speed of a machine operating as a motor (i.e., to create an opposition torque acting against the torque produced by the motor to rotate). In this case, the Four-Quadrant Dynamometer/Power Supply operates as a brake.

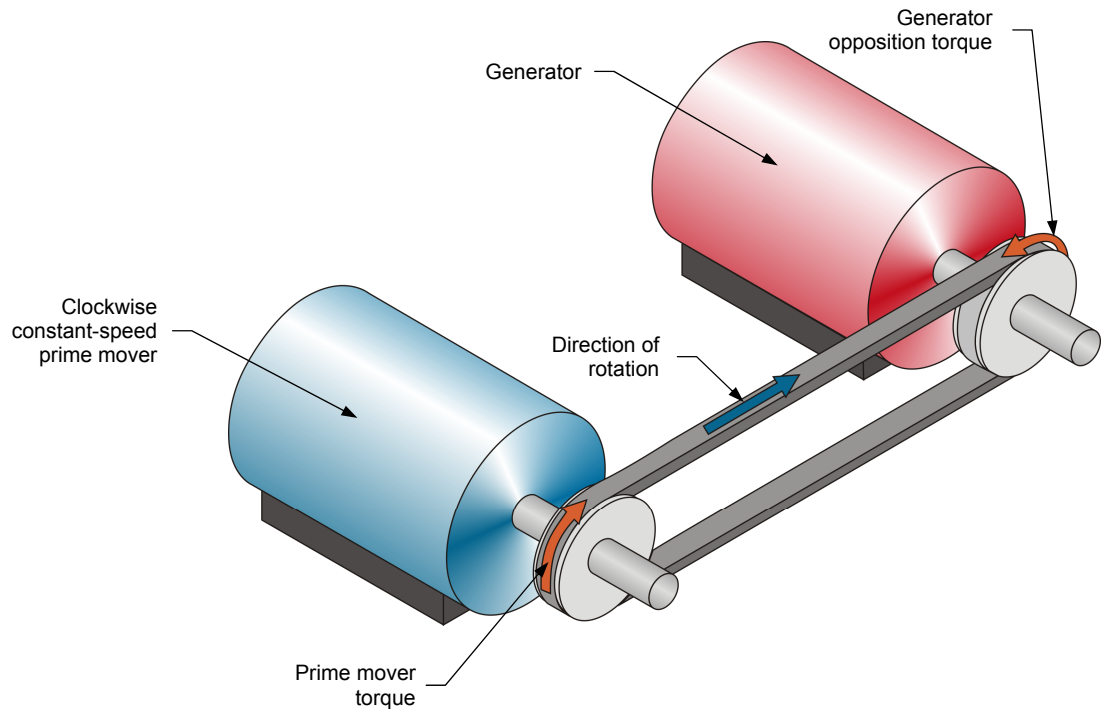

Figure 9. Clockwise constant-speed prime mover coupled to a generator.

When the Four-Quadrant Dynamometer/Power Supply is operating as a clockwise constant-speed prime mover/brake, it is possible to set the rotation speed. In the Four-Quadrant Dynamometer/Power Supply window, speed, torque, power, and energy meters indicate the different parameters measured for the machine under test.

The Four-Quadrant Dynamometer/Power Supply operating as a clockwise constant-speed prime mover maintains constant the speed of the machine to which it is connected. When the machine speed differs from the specified value, the Four-Quadrant Dynamometer/Power Supply automatically adjusts the torque it produces in order to maintain the machine speed to the specified value.

Counterclockwise constant-speed prime mover/brake

This function is identical to the clockwise constant-speed prime mover/brake, except that it makes the Four-Quadrant Dynamometer/Power Supply rotate in the counterclockwise direction. The polarity of the parameters measured for the machine under test is modified accordingly.

Speed, torque, and mechanical power measurements using the Four-Quadrant Dynamometer/Power Supply

By convention, the speed of a machine rotating in the clockwise direction is of positive polarity while the speed of a machine rotating in the counterclockwise direction is of negative polarity.

The polarity of the torque and mechanical power measured for the machine connected to the Four-Quadrant Dynamometer/Power Supply depends on the machine's mode of operation. There are two modes of operation: motor and generator.

Motor operation

As Figure 8 shows, when a machine operates as a motor, the motor torque is in the same direction as the motor's direction of rotation, i.e., the speed at which the motor rotates is of the same polarity as the torque produced by the motor. Consequently, the mechanical power produced by the motor, which is proportional to the product of the motor speed and torque, is always positive, regardless of the motor's direction of rotation (i.e., regardless of whether the motor speed and torque are positive or negative). This is consistent with the definition of a motor, which states that a motor uses electrical energy to produce mechanical energy, thus resulting in a positive mechanical power value.

Any load torque applied to the motor (such as the load torque created by the brake in Figure 8) acts against the torque produced by the motor, and thus has a polarity that is opposite to the polarity of the motor torque and speed.

Generator operation

As Figure 9 shows, when a machine operates as a generator, the generator torque is in the direction opposite to the direction of rotation, i.e., the speed at which the generator rotates has a polarity opposite to the polarity of the torque produced by the generator. Consequently, the mechanical power at the shaft of the generator, which is proportional to the product of the motor speed and torque, is always negative, regardless of the generator's direction of rotation (i.e., regardless of whether the generator speed is positive or negative). This is consistent with the definition of a generator, which states that a generator uses mechanical energy to produce electrical energy, thus resulting in a negative mechanical power value.

The torque produced by the machine driving the generator (such as the prime mover torque in Figure 9) acts against the generator torque and thus has the same polarity as the generator speed.

PROCEDURE OUTLINE

The Procedure is divided into the following sections:

- Setup and connections
- Two-quadrant, constant-torque brake operation
- Constant-speed prime mover operation
- Constant-speed prime mover driving a loaded generator

PROCEDURE



High voltages are present in this laboratory exercise. Do not make or modify any banana jack connections with the power on unless otherwise specified

Setup and connections



Before performing this exercise, measure the open-circuit voltage across the [Lead-Acid Battery Pack \(Model 8802\)](#), using a multimeter. If the open-circuit voltage is lower than 51.2 V, ask your instructor for assistance as the [Lead-Acid Battery Pack](#) is probably not fully charged. Appendix D of this manual indicates how to fully charge the [Lead-Acid Battery Pack](#) before a lab period.

In this section, you will mechanically couple the [Permanent Magnet DC Motor](#) to the [Four-Quadrant Dynamometer/Power Supply](#). You will then set the equipment to study the two-quadrant, constant-torque brake operation.

1. Refer to the Equipment Utilization Chart in Appendix A to obtain the list of equipment required to perform the exercise.

Install the equipment in the [Workstation](#).

Mechanically couple the [Permanent Magnet DC Motor](#) to the [Four-Quadrant Dynamometer/Power Supply](#) using a timing belt.



Before coupling rotating machines, make absolutely sure that power is turned off to prevent any machine from starting inadvertently.

2. Make sure that the main power switch on the [Four-Quadrant Dynamometer/Power Supply](#) is set to the O (off) position, then connect its [Power Input](#) to an ac power wall outlet.
3. Connect the USB port of the [Four-Quadrant Dynamometer/Power Supply](#) to a USB port of the host computer.
4. On the [Permanent Magnet DC Motor](#), make sure that switch S_1 is set to the O (off) position.

5. Connect the equipment as shown in Figure 10. The red motor terminal is the positive terminal.

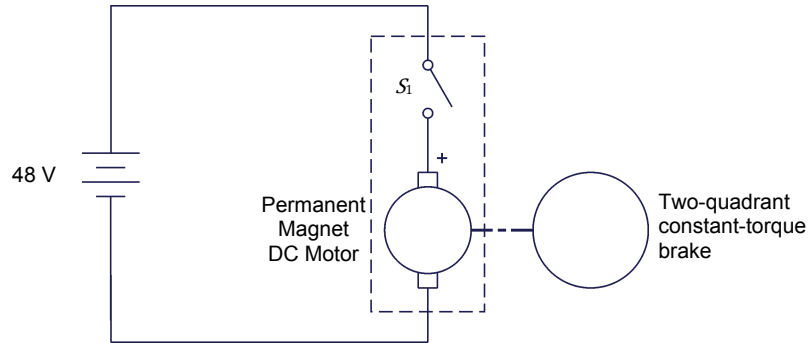

Figure 10. Permanent magnet dc motor coupled to a brake.



Appendix C shows in more detail the equipment and the connections that are required for each circuit diagram symbol used in this manual.

6. On the **Four-Quadrant Dynamometer/Power Supply**, set the *Operating Mode* switch to *Dynamometer*. This setting allows the **Four-Quadrant Dynamometer/Power Supply** to operate as a prime mover, a brake, or both, depending on the selected function.

Turn the **Four-Quadrant Dynamometer/Power Supply** on by setting the main power switch to I (on).

7. Turn the host computer on, then start the **LVDAC-EMS** software.

In the **LVDAC-EMS Start-Up** window, make sure that the **Four-Quadrant Dynamometer/Power Supply** is detected. Also, select the network voltage and frequency that correspond to the voltage and frequency of your local ac power network, then click the **OK** button to close the **LVDAC-EMS Start-Up** window.

8. In **LVDAC-EMS**, open the **Four-Quadrant Dynamometer/Power Supply** window, then make the following settings:
 - Set the *Function* parameter to *Two-Quadrant, Constant-Torque Brake*. This setting makes the **Four-Quadrant Dynamometer/Power Supply** operate as a two-quadrant brake with a torque setting corresponding to the *Torque* parameter.
 - Set the *Pulley Ratio* parameter to 24:12. The first and second numbers in this parameter specify the number of teeth on the pulley of the **Four-Quadrant Dynamometer/Power Supply** and the number of teeth on the pulley of the machine under test (i.e., the **Permanent Magnet DC Motor**), respectively. It is important to ensure that the *Pulley Ratio* parameter corresponds to the actual pulley ratio between the **Four-Quadrant Dynamometer/Power Supply** and the machine under test.

- Make sure that the *Torque Control* parameter is set to *Knob*. This allows the torque of the two-quadrant brake to be controlled manually.
- Set the *Torque* parameter to the minimum value (0.0 N·m or 0.0 lbf·in) by entering this value in the field next to this parameter. This sets the torque command of the *Two-Quadrant, Constant-Torque Brake* to 0.0 N·m (0.0 lbf·in).



The torque command can also be set by using the *Torque* control knob in the *Four-Quadrant Dynamometer/Power Supply* window.

Two-quadrant, constant-torque brake operation

In this section, you will make the Permanent Magnet DC Motor rotate in the clockwise direction and observe what happens to the torque produced by the motor when you increase the load torque applied to it. You will observe the polarity of the torque and the mechanical power produced by the Permanent Magnet DC Motor, and confirm that this machine is operating as a motor. You will then make the Permanent Magnet DC Motor rotate in the counterclockwise direction and observe what happens to the torque produced by the motor when you increase the load torque applied to it. You will observe the polarity of the torque and mechanical power produced by the Permanent Magnet DC Motor, and confirm that the machine can operate as a motor, in either direction of rotation (clockwise or counterclockwise).

9. In the *Four-Quadrant Dynamometer/Power Supply* window, start the *Two-Quadrant, Constant-Torque Brake* by setting the Status parameter to *Started* or by clicking the *Start/Stop* button.

On the *Permanent Magnet DC Motor*, set switch S_1 to the I (on) position. Observe that the motor starts rotating. This is because the *Lead-Acid Battery Pack* acts as a dc power source supplying power to the *Permanent Magnet DC Motor* to make it rotate.

The *Speed* meter in the *Four-Quadrant Dynamometer/Power Supply* window indicates the rotation speed n of the *Permanent Magnet DC Motor*. Is this speed positive, indicating that the motor is rotating in the clockwise direction?

Yes No

10. In the *Four-Quadrant Dynamometer/Power Supply* window, slowly increase the value of the *Torque* parameter to 0.5 N·m (4.4 lbf·in). While you do so, observe the torque T produced by the *Permanent Magnet DC Motor* (indicated by the *Torque* meter in the *Four-Quadrant Dynamometer/Power Supply* window).

What happens to the torque T produced by the *Permanent Magnet DC Motor* as the load torque applied to the motor by the *Two-Quadrant, Constant-Torque Brake* increases?

11. What is the polarity of the torque T produced by the Permanent Magnet DC Motor?

What is the polarity of the Permanent Magnet DC Motor speed n ?

Is the torque T of the same polarity as the motor speed n ?

- Yes No

12. Is the polarity of the motor mechanical power P_M positive (indicated by the Power meter in the Four-Quadrant Dynamometer/Power Supply window)?

- Yes No

Does this confirm that the Permanent Magnet DC Motor currently operates as a motor? Explain.

13. Stop the Permanent Magnet DC Motor by setting its power switch S_1 to the O (off) position.

In the Four-Quadrant Dynamometer/Power Supply window, set the Torque parameter to 0.0 N·m (0.0 lbf·in).

14. On the Lead-Acid Battery Pack, reverse the battery connections to reverse the polarity of the voltage applied to the Permanent Magnet DC Motor.



Reversing the power supply connections at the two terminals of a dc motor reverses the direction of rotation of the motor.

Start the Permanent Magnet DC Motor by setting its power switch S_1 to the I (on) position. Is the Permanent Magnet DC Motor speed n negative, indicating that the direction of rotation of the motor has been reversed and that the motor is rotating in the counterclockwise direction?

- Yes No

15. In the Four-Quadrant Dynamometer/Power Supply window, slowly increase the value of the Torque parameter to 0.5 N·m (4.4 lbf·in). While you do so, observe the torque T produced by the Permanent Magnet DC Motor.

What happens to the torque T produced by the **Permanent Magnet DC Motor** as the braking torque applied to the motor by the *Two-Quadrant, Constant-Torque Brake* increases?

16. Is the torque T produced by the **Permanent Magnet DC Motor** of the same polarity as the motor speed n ?

Yes No

17. Is the polarity of the motor mechanical power P_M positive?

Yes No

Does this confirm that the **Permanent Magnet DC Motor** currently operates as a motor?

Yes No

18. Stop the **Permanent Magnet DC Motor** by setting its power switch S_1 to the O (off) position.

In the *Four-Quadrant Dynamometer/Power Supply* window, stop the *Two-Quadrant, Constant-Torque Brake* by setting the Status parameter to *Stopped* or by clicking the *Start/Stop* button.

19. From your observations, does the direction of rotation of the **Permanent Magnet DC Motor** determine the polarity (positive or negative) of the motor speed n and torque T ? Explain.

Can the **Permanent Magnet DC Motor** operate as a motor in either direction of rotation (clockwise or counterclockwise)? Explain.

Constant-speed prime mover operation

In this section, you will set up a circuit containing a prime mover (implemented using the Four-Quadrant Dynamometer/Power Supply) mechanically coupled to the Permanent Magnet DC Motor. You will make the prime mover rotate in the clockwise direction and confirm that the Permanent Magnet DC Motor rotates at the specified speed determined by the prime mover speed and the pulley ratio. You will also confirm that the torque produced by the machine is virtually zero. You will make the prime mover rotate in the counterclockwise direction and confirm that the speed of the Permanent Magnet DC Motor is negative when it rotates in the counterclockwise direction. You will also confirm that the torque produced by the machine is virtually zero.

20. Set up the equipment as shown in Figure 11. In this circuit, no load is connected to the Permanent Magnet DC Motor output.

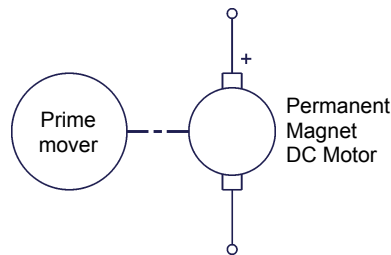

Figure 11. Prime mover coupled to a permanent magnet dc motor (no electrical load connected to the motor).

21. In the Four-Quadrant Dynamometer/Power Supply window, make the following settings:

- Set the *Function* parameter to *CW Constant-Speed Prime Mover/Brake*. This setting makes the Four-Quadrant Dynamometer/Power Supply operate as a clockwise prime mover/brake with a speed setting corresponding to the *Speed* parameter.
- Set the *Pulley Ratio* parameter to 24:12.
- Make sure that the *Speed Control* parameter is set to *Knob*. This allows the speed of the clockwise prime/mover brake to be controlled manually.
- Set the *Speed* parameter (i.e., the speed command) to 1000 r/min by entering 1000 in the field next to this parameter. Notice that the speed command is the targeted speed at the shaft of the machine coupled to the prime mover, i.e., the speed of the Permanent Magnet DC Motor in the present case.



The speed command can also be set by using the *Speed control knob* in the Four-Quadrant Dynamometer/Power Supply window.

22. In the Four-Quadrant Dynamometer/Power Supply window, start the *CW Constant-Speed Prime Mover/Brake* by clicking the *Start/Stop* button or by setting the *Status* parameter to *Started*.

Observe that the prime mover starts to rotate, thereby driving the shaft of the **Permanent Magnet DC Motor**.

In the **Four-Quadrant Dynamometer/Power Supply** window, observe that the **Pulley Ratio** parameter is now grayed out as it cannot be changed while the prime mover is rotating. The **Speed** meter indicates the rotation speed n of the **Permanent Magnet DC Motor**. Record this speed below.

Rotation speed of the permanent magnet dc motor = _____ r/min

Is the rotation speed of the **Permanent Magnet DC Motor** approximately equal to the value of the **Speed** parameter?

Yes No

Is the rotation speed positive, indicating that the **Permanent Magnet DC Motor** is rotating in the clockwise direction?

Yes No

- 23.** Observe the rotation speed indicated on the front panel display of the **Four-Quadrant Dynamometer/Power Supply** module. It corresponds to the rotation speed of the prime mover. Notice that this speed is approximately half ($\cong 500$ r/min) the speed of the **Permanent Magnet DC Motor**. This is because the pulley ratio of 24:12 causes the prime mover to make $\frac{1}{2}$ ($12 \div 24$) revolution for every revolution of the **Permanent Magnet DC Motor**. Is this your observation?

Yes No

- 24.** In the **Four-Quadrant Dynamometer/Power Supply** window, observe the torque T of the **Permanent Magnet DC Motor**.

Is the torque virtually zero, indicating that no torque is produced by the **Permanent Magnet DC Motor**?

Yes No

- 25.** In the **Four-Quadrant Dynamometer/Power Supply** window, increase the **Speed** parameter to 1500 r/min.

Does the speed n of the **Permanent Magnet DC Motor** increase with the **Speed** parameter of the **CW Constant-Speed Prime Mover/Brake**?

Yes No

Does the motor torque T remain virtually zero as the speed increases?

Yes No

26. In the *Four-Quadrant Dynamometer/Power Supply* window, stop the *CW Constant-Speed Prime Mover/Brake* by clicking the *Start/Stop* button or by setting the *Status* parameter to *Stopped*, then make the following settings:

- Set the *Function* parameter to *CCW Constant-Speed Prime Mover/Brake*. This setting makes the *Four-Quadrant Dynamometer/Power Supply* operate as a counterclockwise prime mover/brake with a speed setting corresponding to the *Speed* parameter.
- Set the *Pulley Ratio* parameter to 24:12.
- Make sure that the *Speed Control* parameter is set to *Knob*. This allows the speed of the counterclockwise prime/mover brake to be controlled manually.
- Set the *Speed* parameter to –1000 r/min.

27. In the *Four-Quadrant Dynamometer/Power Supply* window, start the *CCW Constant-Speed Prime Mover/Brake* by clicking the *Start/Stop* button or by setting the *Status* parameter to *Started*.

28. Wait a few seconds, then observe the *Permanent Magnet DC Motor* speed and torque.

Is the rotation speed of the *Permanent Magnet DC Motor* approximately equal to the value of the *Speed* parameter?

- Yes No

Is the motor speed n negative, indicating that the *Permanent Magnet DC Motor* is rotating in the counterclockwise direction?

- Yes No

Is the motor torque T virtually zero, indicating that no torque is produced by the *Permanent Magnet DC Motor*?

- Yes No

29. In the *Four-Quadrant Dynamometer/Power Supply* window, increase the *Speed* parameter to –1500 r/min.

Does the speed n of the *Permanent Magnet DC Motor* increase (with a negative polarity) as the *Speed* parameter of the *CCW Constant-Speed Prime Mover/Brake* increases?

- Yes No

Does the motor torque T remain virtually zero as the speed increases?

- Yes No

30. In the *Four-Quadrant Dynamometer/Power Supply* window, stop the *CCW Constant-Speed Prime Mover/Brake* by clicking the *Start/Stop* button or by setting the *Status* parameter to *Stopped*.

Constant-speed prime mover driving a loaded generator

In this section, you will set up a circuit containing a prime mover (implemented using the *Four-Quadrant Dynamometer/Power Supply*) mechanically coupled to the *Permanent Magnet DC Motor* operating as a generator. The output of the generator will be short circuited. You will make the generator rotate in the clockwise direction and confirm that the generator speed and torque are of opposite polarity, and that the generator mechanical power is negative, thus indicating that the machine is operating as a generator. You will then make the generator rotate in the counterclockwise direction and verify that the generator speed and torque are of opposite polarity, and that the generator mechanical power is negative. Finally, you will confirm that the machine can operate as a generator, regardless of the direction of rotation.

31. Connect the equipment as shown in Figure 12.

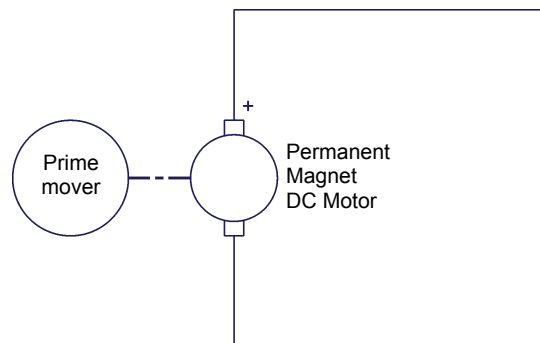

Figure 12. Prime mover coupled to a permanent magnet dc motor operating as a generator (short-circuited output).

32. In the *Four-Quadrant Dynamometer/Power Supply* window, make the following settings:
- Set the *Function* parameter to *CW Constant-Speed Prime Mover/Brake*.
 - Set the *Pulley Ratio* parameter to 24:12.
 - Make sure that the *Speed Control* parameter is set to *Knob*.
 - Set the *Speed* parameter to 1000 r/min.
33. In the *Four-Quadrant Dynamometer/Power Supply* window, start the *CW Constant-Speed Prime Mover/Brake* to make the *Permanent Magnet DC Motor* rotate.

34. What is the polarity of the torque T produced by the Permanent Magnet DC Motor?

What is the polarity of the Permanent Magnet DC Motor speed n ?

Are the speed and torque of opposite polarity?

Yes No

35. Is the polarity of the motor mechanical power negative?

Yes No

Does this confirm that the Permanent Magnet DC Motor currently operates as a generator? Explain.

-
36. Slowly increase the Speed parameter to 1500 r/min. While you do so, observe the speed n , torque T , and mechanical power P_M of the Permanent Magnet DC Motor on the meters in the Four-Quadrant Dynamometer/Power Supply.

Describe what happens to the torque and mechanical power as the speed increases.

-
37. Observe the rotation speed indicated on the front panel display of the Four-Quadrant Dynamometer/Power Supply module. It corresponds to the rotation speed of the prime mover. Notice that this speed is approximately half ($\cong 750$ r/min) the generator speed. This is because the pulley ratio of 24:12 causes the prime mover to make $\frac{1}{2}$ ($12 \div 24$) revolution for every revolution of the generator. Is this your observation?

Yes No

Also, observe the torque indicated on the front panel display of the Four-Quadrant Dynamometer/Power Supply module. It corresponds to the torque of the prime mover. Notice that this torque is approximately twice the generator torque. This is because the pulley ratio of 24:12 causes the prime mover torque to be 2 times ($24 \div 12$) greater than the generator torque. Is this your observation?

Yes No

- 38.** In the *Four-Quadrant Dynamometer/Power Supply* window, stop the *CW Constant-Speed Prime Mover/Brake*, then make the following setting:
- Set the *Function* parameter to *CCW Constant-Speed Prime Mover/Brake*.
 - Set the *Pulley Ratio* parameter to 24:12.
 - Make sure that the *Speed Control* parameter is set to *Knob*.
 - Set the *Speed* parameter to –1000 r/min.
 - Start the *CCW Constant-Speed Prime Mover/Brake* to make the *Permanent Magnet DC Motor* rotate.
- 39.** Slowly increase the *Speed* parameter to -1500 r/min. Describe what happens to the torque T as the speed increases.

Are the generator speed n and torque T of opposite polarity?

- Yes No

- 40.** Is the polarity of the motor mechanical power P_M negative?

- Yes No

Does this confirm that the *Permanent Magnet DC Motor* currently operates as a generator?

- Yes No

- 41.** In the *Four-Quadrant Dynamometer/Power Supply* window, stop the *CCW Constant-Speed Prime Mover/Brake* by setting the *Status* parameter to *Stopped* or by clicking the *Start/Stop* button.

- 42.** From your observations, does the direction of rotation determine the polarity of the generator speed n and torque T ? Explain.

Can the **Permanent Magnet DC Motor** operate as a generator in either direction of rotation (clockwise or counterclockwise)?

- Yes No

- 43.** Turn the **Four-Quadrant Dynamometer/Power Supply** off by setting the main power switch to **O** (off). Close the **LVDAC-EMS** software. Disconnect all leads and return them to their storage location.

CONCLUSION

In this exercise, you familiarized yourself with the basic functions of the Four-Quadrant Dynamometer/Power Supply used in this manual. You observed the polarity of the speed, torque, and mechanical power for a rotating machine operating either as a motor or a generator.

REVIEW QUESTIONS

1. Calculate the power P of a motor rotating at a speed n of 2000 r/min and producing a torque T of 1.2 N·m (10.6 lbf·in).

2. Briefly describe a brake and a prime mover.

3. Briefly describe the energy conversion occurring in a motor, as well as the energy conversion occurring in a generator.

4. Consider a motor rotating in the clockwise direction that is coupled to a brake applying a load torque to the motor. Determine the polarity of the motor speed and torque, as well as the polarity of the braking torque. Also, determine the polarity of the motor mechanical power.

5. Consider a prime mover making a generator rotate in the clockwise direction. Determine the polarity of the prime mover torque, as well as the polarity of the generator speed and torque. Also, determine the polarity of the generator mechanical power.

Permanent Magnet DC Motor Operating as a Generator

EXERCISE OBJECTIVE

When you have completed this exercise, you will be familiar with the construction of permanent magnet dc motors as well as their operation as generators.

DISCUSSION OUTLINE

The Discussion of this exercise covers the following points:

- Permanent magnets
- Magnetic field around a conductor
- Magnetic field in a loop of wire (electromagnet)
- Electromagnetic induction
- Construction of a permanent magnet dc motor
- Permanent magnet dc motor operating as a generator
- Reducing the fluctuations of the generated dc voltage
- Characteristic of the generated voltage as a function of the rotation speed
- Torque opposing rotation in a permanent magnet dc motor operating as a generator
- Opposition torque-versus-current characteristic

DISCUSSION

Permanent magnets

A permanent magnet is a piece of iron or metal surrounded by a magnetic field, as Figure 13 shows. This magnetic field is constant, i.e., it persists naturally without the need of an electrical current. The magnet has a north (N) pole and a south (S) pole. These poles are situated near the ends of the magnet where the magnetic field strength is the greatest.

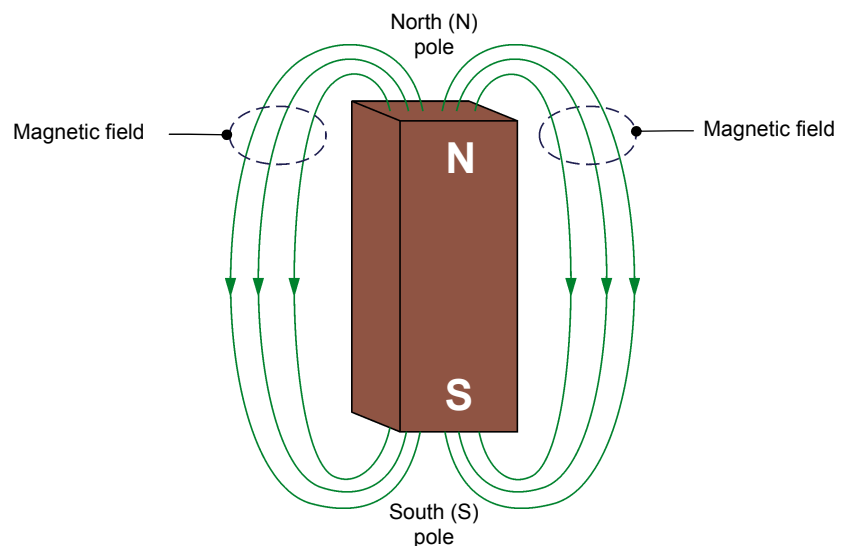

Figure 13. A permanent magnet has two poles called north (N) and south (S).

The direction of the magnetic field is indicated by the line arrows: from north to south outside the magnet, and from south to north within the magnet.

Like poles on magnets repel each other while unlike poles attract each other, as Figure 14 shows.

- **Repulsion:** when a pole on a magnet is moved toward a pole of similar polarity on another magnet, the magnets repel each other, as Figure 14a shows.
- **Attraction:** when a pole on a magnet is moved toward a pole of opposite polarity on another magnet, the magnets attract each other, as Figure 14b shows.

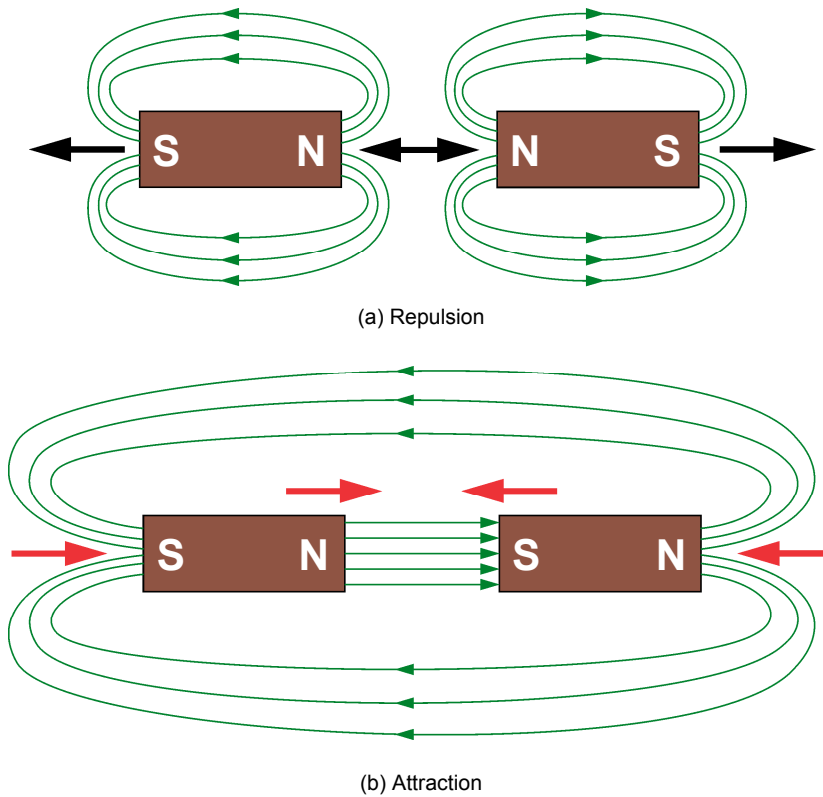

Figure 14. Like poles repel each other while opposite poles attract each other.

Magnetic field around a conductor

When electrical current flows through a conductor like an electric wire, a magnetic field is created. The magnetic field is represented by concentric lines centered around the wire axis, as Figure 15 shows. The direction of the magnetic field lines can be determined by using the right-hand rule, as Figure 15 shows.

- The thumb represents the direction of the current in the conductor.
- The other fingers represent the direction of the magnetic field lines.

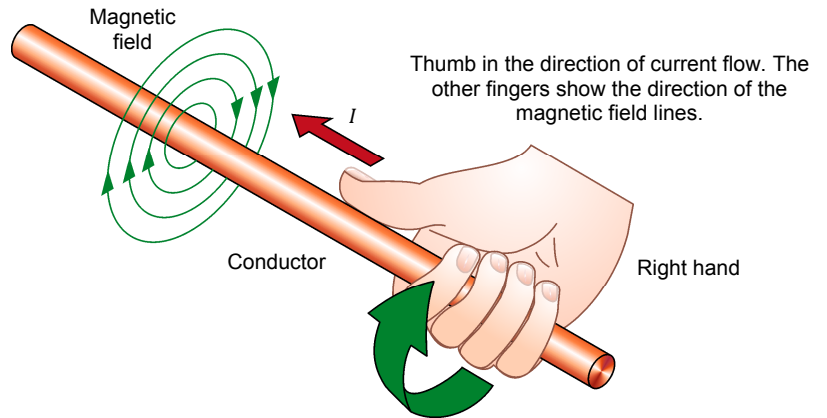

Figure 15. When electrical current flows through a conductor, a magnetic field is created around the conductor.

Magnetic field in a loop of wire (electromagnet)

When current flows through a loop of wire, a magnetic field is created in the loop. As Figure 16 shows, this magnetic field has north and south poles, like a permanent magnet. In this condition, the loop of wire forms an **electromagnet**.

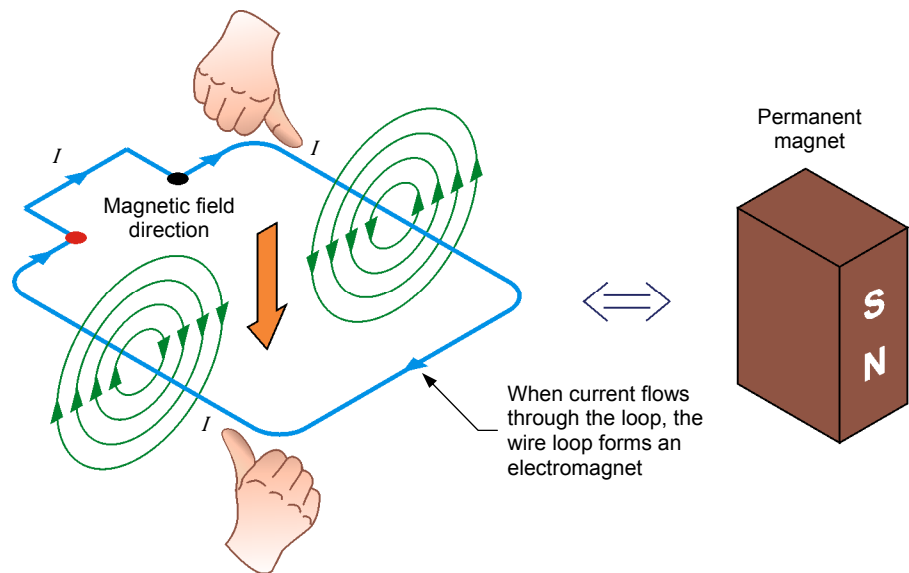

Figure 16. Magnetic field created in a loop of wire.

By using the right-hand rule, the direction of the magnetic field inside the loop of wire and, therefore, the location of the north and south poles can be determined. The higher the current flowing through the loop, the stronger the magnetic field produced in the loop. When the current flow is interrupted, the magnetic field disappears.



Figure 17. Permanent magnet dc generators can be used for battery charging.



Figure 18. Permanent magnet dc generators can be used in small-scale wind turbines.

Electromagnetic induction

The operation of various electric devices (transformers, generators, alternators, motors, etc.) is based on Faraday's law of **electromagnetic induction**, which states the following:

1. A voltage is induced across the terminals of a wire loop if the magnetic flux passing through the loop varies as a function of time.
2. The value of the induced voltage is proportional to the rate of change of the magnetic flux.

The voltage induced across the terminals of a wire loop when the magnetic flux passing through the loop varies can be calculated using the following equation:

$$E = N_{Turns} \cdot \frac{\Delta\phi}{\Delta t} \quad (7)$$

- where
- E is the voltage induced across the terminals of the wire loop, expressed in volts (V).
 - N_{Turns} is the number of turns of wire in the loop.
 - $\Delta\phi$ is the variation in intensity of the magnetic flux passing through the wire loop, expressed in Webers (Wb).
 - Δt is the time interval during which the magnetic flux variation occurs, expressed in seconds (s).

Figure 19 gives an example of the voltage induced across a wire loop that is exposed to a magnetic flux varying in intensity. Between instants t_0 and t_1 , the intensity of the magnetic flux ϕ remains constant (3 mWb), and thus, the induced voltage is zero. Between instants t_1 and t_2 , the intensity of the magnetic flux ϕ increases at a constant rate, and thus, a constant voltage is induced in the wire loop. Between instants t_2 and t_3 , the intensity of the magnetic ϕ flux remains constant (5 mWb), and thus, the induced voltage is zero.

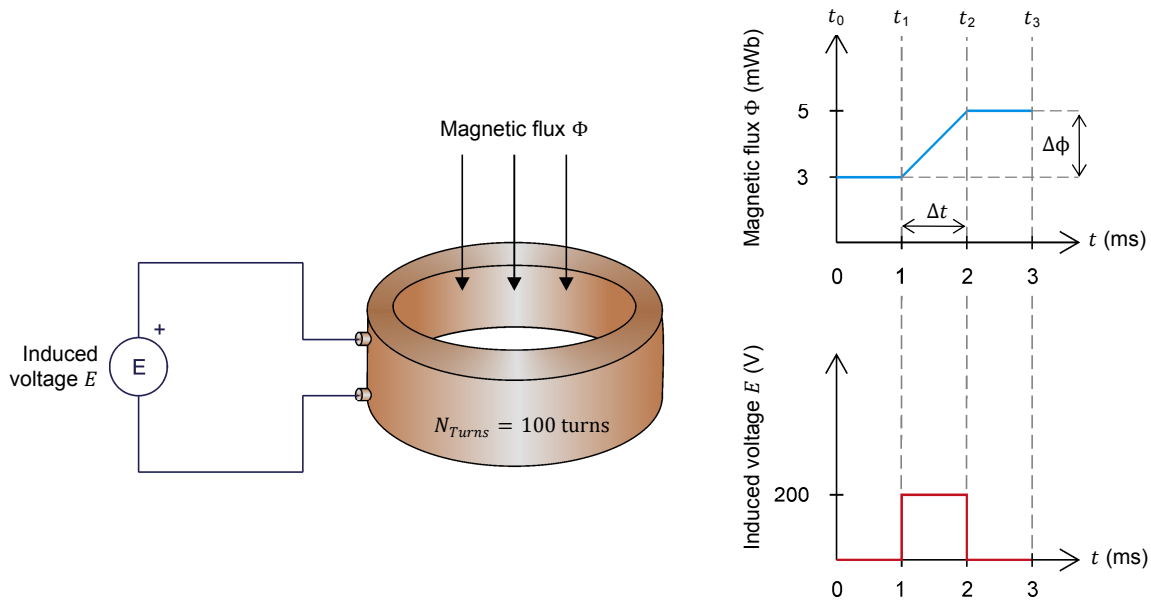

Figure 19. Voltage induced in a loop exposed to a magnetic flux varying in intensity.

Using the values given in Figure 19, the voltage E induced across the coil between instants t_1 and t_2 can be calculated by using Equation (7):

$$E = N_{Turns} \cdot \frac{\Delta\phi}{\Delta t} = 100 \text{ turns} \cdot \frac{0.005 \text{ Wb} - 0.003 \text{ Wb}}{0.001 \text{ s}} = 200 \text{ V}$$

Figure 20 shows another example illustrating electromagnetic induction. Two permanent magnets are aligned so that poles of opposite polarities face each other. This creates a magnetic field going from left to right between the magnets, as indicated by the lines of magnetic field shown in the figure. As the wire loop is moved upward between the two magnets, the magnetic flux ϕ that passes through the loop increases up to a maximum value then returns to zero, and thus, voltage is induced across the loop terminals.

- In Figure 20a, the lines of magnetic field pass from the A side of the wire loop to the B side of the wire loop, resulting in a magnetic flux ϕ of negative polarity through the loop. The voltage V_{AB} induced across the loop terminals has a negative polarity when the magnetic flux passes from zero to the negative maximum, because the rate of change $\frac{\Delta\phi}{\Delta t}$ of the magnetic flux has a negative value. The induced voltage V_{AB} is zero when the magnetic flux ϕ reaches the negative maximum because the magnetic flux momentarily stops varying (i.e., the rate of change $\frac{\Delta\phi}{\Delta t}$ of the magnetic flux is zero). The induced voltage V_{AB} reverses polarity (i.e., it becomes positive) when the magnetic flux passes from the negative maximum to zero because the rate of change $\frac{\Delta\phi}{\Delta t}$ of the magnetic flux has a positive value.

- In Figure 20b, the same wire loop is moved upward between the two magnets. However, the loop has been rotated 180° so that the lines of magnetic field pass from the B side of the loop to the A side of the loop, resulting in a magnetic flux ϕ of positive polarity through the loop (i.e., the polarity of the magnetic flux is opposite to that in Figure 20a). Consequently, the magnetic flux ϕ and the voltage V_{AB} induced across the loop are similar to those in Figure 20a but are of opposite polarity. Thus, the voltage V_{AB} induced across the loop terminals has a positive polarity when the magnetic flux passes from zero to the positive maximum, because the rate of change $\frac{\Delta\phi}{\Delta t}$ of the magnetic flux has a positive value. The induced voltage V_{AB} is zero when the magnetic flux ϕ reaches the positive maximum because the magnetic flux momentarily stops varying. The induced voltage V_{AB} reverses polarity (i.e., it becomes negative) when the magnetic flux passes from the positive maximum to zero because the rate of change $\frac{\Delta\phi}{\Delta t}$ of the magnetic flux has a negative value.

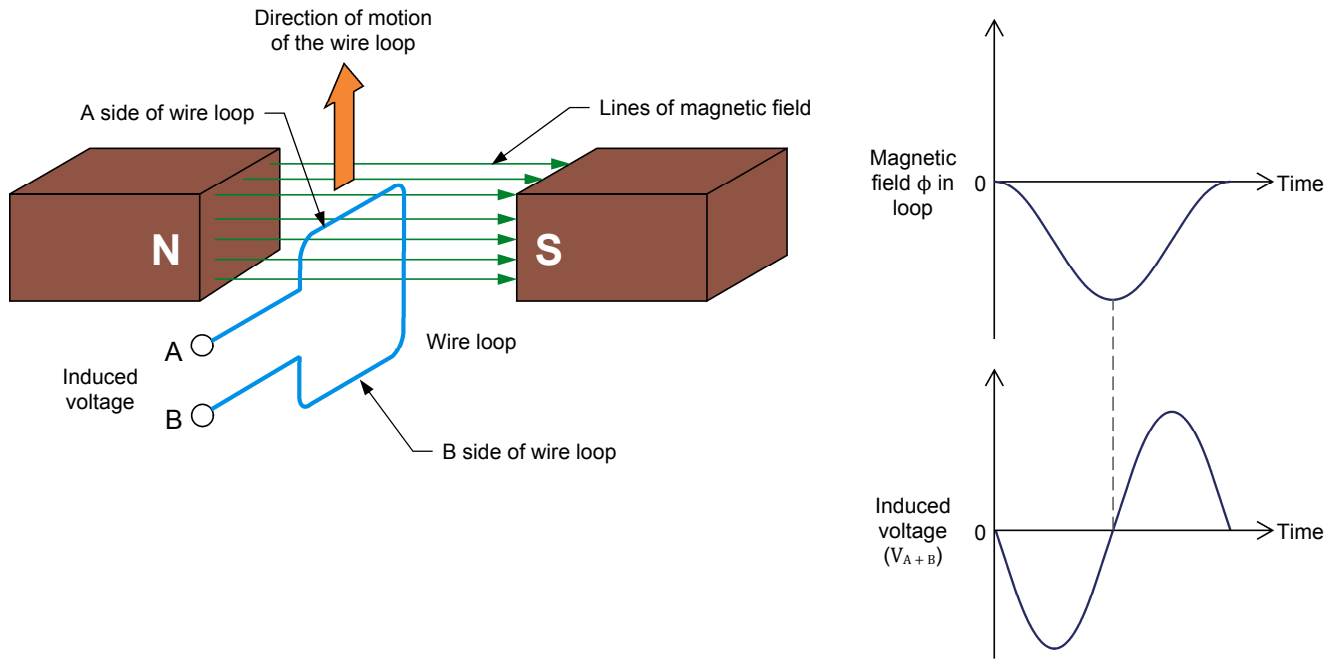

(a) The lines of magnetic field pass from the A side to the B side of the wire loop.

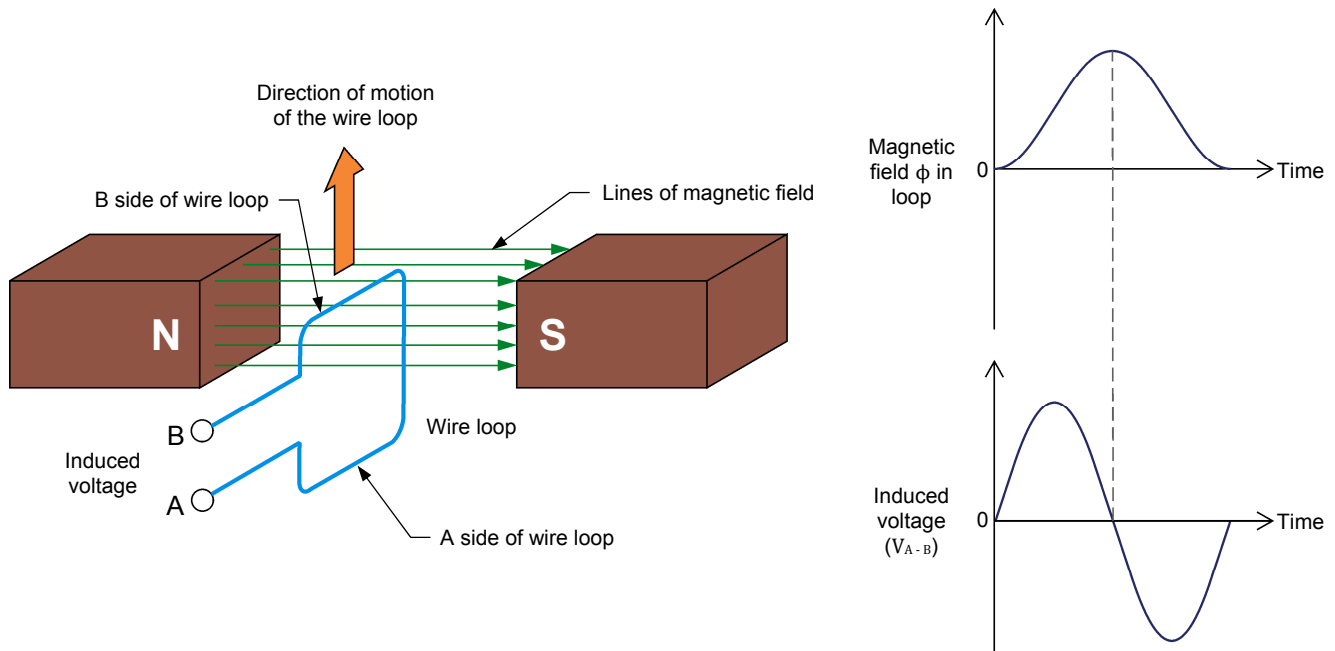

(b) The lines of magnetic field pass from the B side to the A side of the wire loop.

Figure 20. Voltage induced across a wire loop that is moved in the magnetic field created by permanent magnets.

Construction of a permanent magnet dc motor

Figure 21 shows a simplified diagram of a permanent magnet dc motor.

- The **stator** is the fixed part of the motor, in which the **rotor** turns. The stator consists of a pair of permanent magnets aligned so that poles of opposite polarities face each other. Thus, one magnet has its north (N) pole close to the **armature**, while the other magnet has its south (S) pole close to the armature. Therefore, lines of magnetic field pass from one permanent magnet to the other through the metallic armature.
- The rotor is the rotating part of the motor. It consists of a wire loop mounted on a rotary metallic armature. The ends of the wire loop are connected to terminals located on the stator of the motor, via a **commutator** and a pair of brushes (usually made of carbon). The commutator has two segments isolated from one another. Each segment is connected to one terminal of the wire loop. (The role of the commutator will be explained later.)

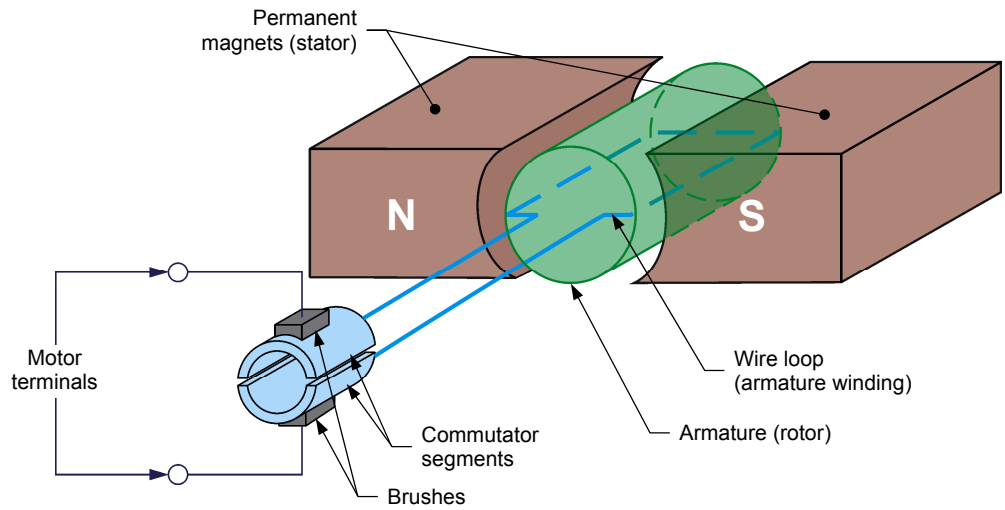

Figure 21. Construction of a simple permanent magnet dc motor.

Such a dc motor is referred to as a permanent magnet dc motor because permanent magnets are used to produce the magnetic field necessary for operation.

The diagram in Figure 21 shows the simplest way of constructing a permanent magnet dc motor. In real dc motors, the armature is made up of several wire loops instead of a single loop and the commutator has several segments instead of a single pair of segments. Also, each wire loop consists of several turns of wire instead of a single turn.

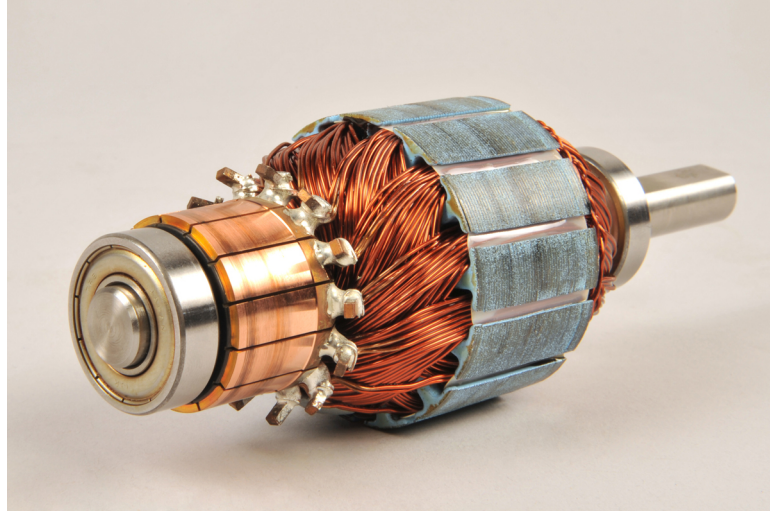

Figure 22. In real dc motors, the armature (rotor) is made up of several wire loops and the commutator has several segments.

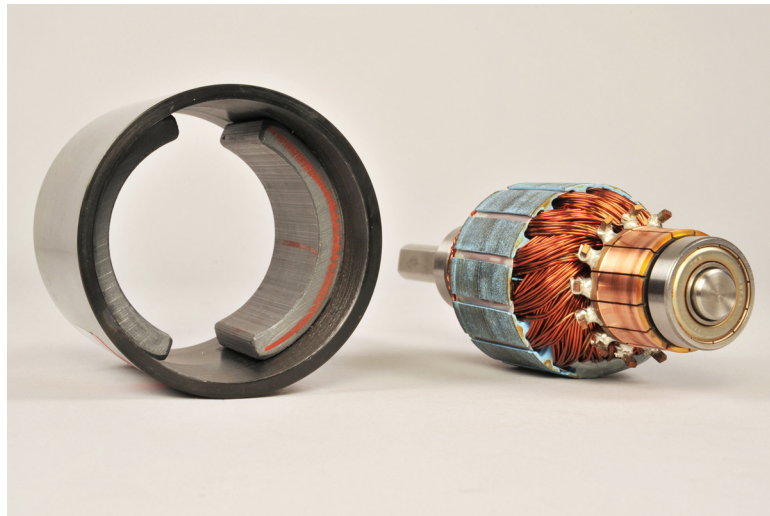

Figure 23. Motor stator and rotor. The stator is the fixed part of the motor, in which the rotor turns. The stator consists of a pair of permanent magnets aligned so that poles of opposite polarities face each other.

Permanent magnet dc motor operating as a generator

Figure 24 shows a permanent magnet dc motor operating as a generator. When the rotor wire loop is rotated within the magnetic field produced by the stator permanent magnets, the magnetic flux ϕ that passes through the loop varies and a voltage, E_1 , is induced across the loop terminals. Voltage E_1 is collected by the two commutator segments and delivered to stationary brushes ($B+$ and $B-$) connected to the motor terminals.

- As the loop passes from position 0 to position 4, the magnetic flux ϕ in the loop passes from a negative maximum (maximum flux passing from the A side to the B side of the loop) to a positive maximum (maximum

flux passing from the B side to the A side of the loop). During this 180° interval of rotation, the voltage E_1 induced across the loop has a positive polarity because the rate of change $\frac{\Delta\phi}{\Delta t}$ of the magnetic flux has a positive value.

- When the loop reaches position 4, the connections of the two commutator segments to brushes B^- and B^+ are reversed. Consequently, this reverses the connections between the wire loop terminals and the motor terminals.
- As the loop passes from position 4 to position 0, the magnetic flux ϕ in the loop passes from a positive maximum (maximum flux passing from the B side to the A side of the loop) to a negative maximum (maximum flux passing from the A side to the B side of the loop). During this 180° interval of rotation, the voltage E_1 induced across the loop has a negative polarity because the rate of change $\frac{\Delta\phi}{\Delta t}$ of the magnetic flux has a negative value.
- When the loop reaches position 0, the connections of the two commutator segments to brushes B^- and B^+ are reversed again, thereby reversing the connections between the wire loop terminals and the motor terminals.

This cycle repeats as long as the rotor continues to rotate, so that the polarity of the voltage E_1 generated across the rotor wire loop continually alternates: it is positive for half a turn, then negative for the next half turn, then positive for the next half turn, and so on. Because of this, the voltage E_1 generated across the rotor wire loop is referred to as an **alternating-current (ac)** voltage. Because the commutator reverses the connections between the wire loop terminals and the motor terminals at wire loop positions 0 and 4, the voltage E_2 at the motor terminals always has the same polarity (positive), as is shown in Figure 24. The voltage E_2 at the motor terminals is thus a pulsating positive **direct-current (dc)** voltage (two pulses per rotation).

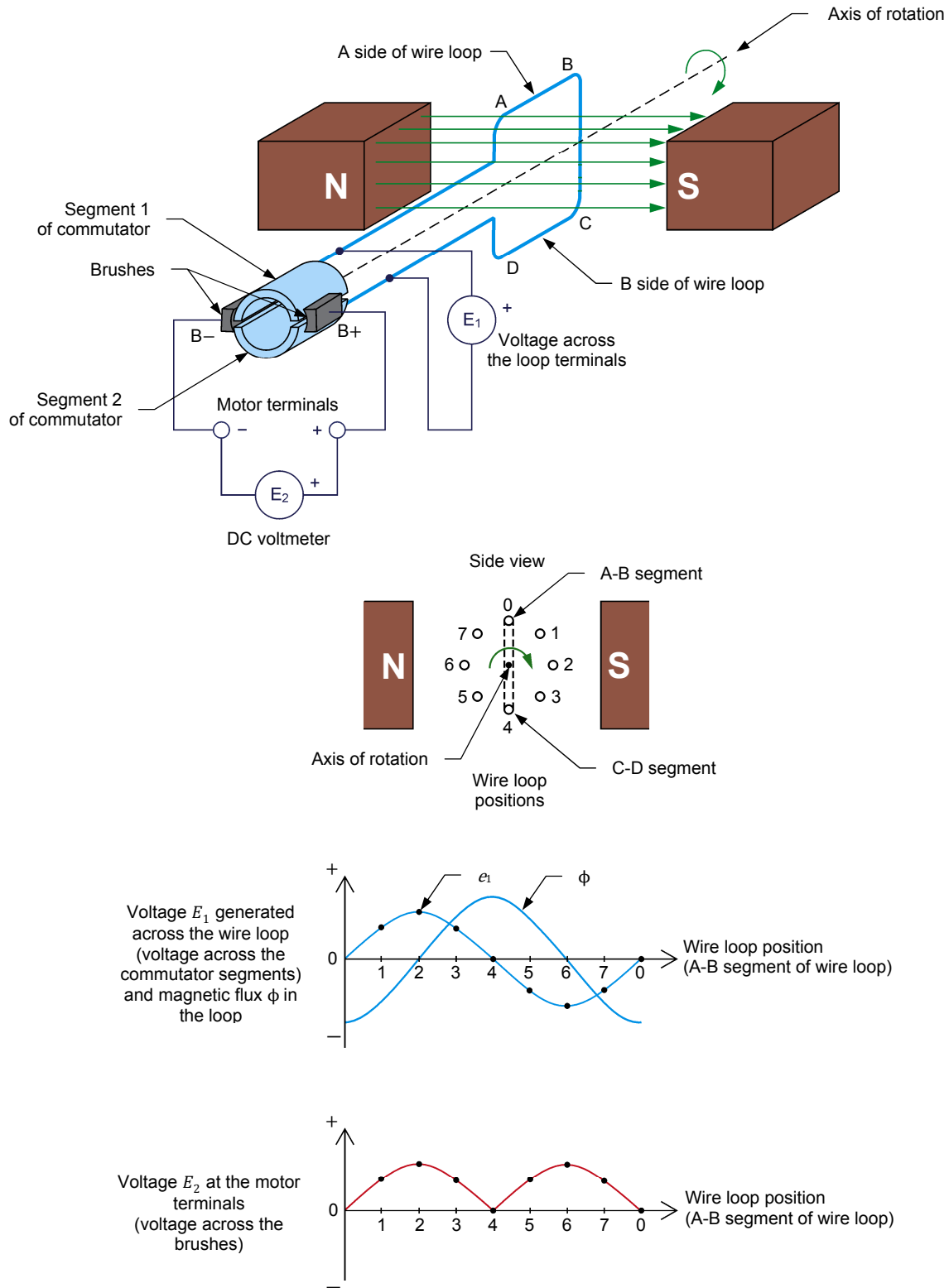

Figure 24. Permanent magnet dc motor operating as a generator (clockwise rotation).

When the direction of rotation of the wire loop is reversed, the polarity of the dc voltage E_2 at the motor terminals also reverses, as Figure 25 shows. The voltage E_2 at the motor terminals is thus a pulsating negative dc voltage (two pulses per rotation).

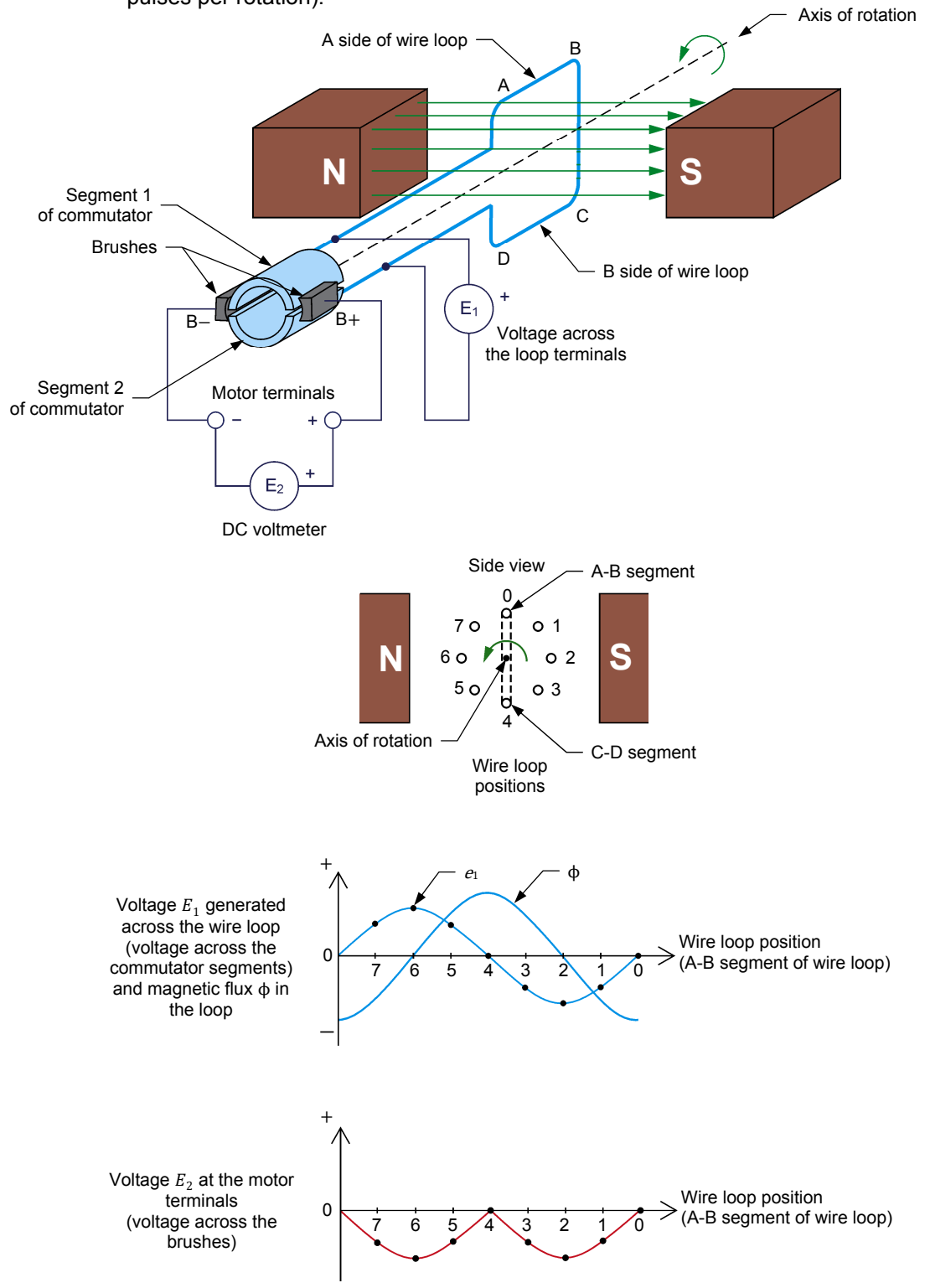

Figure 25. Permanent magnet dc motor operating as a generator (counterclockwise rotation).

Reducing the fluctuations of the generated dc voltage

All permanent magnet dc motors have an armature made of several wire loops and commutator segments. Increasing the number of wire loops and commutator segments reduces the fluctuation of the voltage at the dc motor terminals that is due to the pulsating effect (i.e., the generated voltage is a nearly pure dc voltage). Figure 26 shows an example of the voltage generated at the terminals of a dc motor when a second loop of wire is added to the armature. Two extra segments are also added to the commutator to connect the additional wire loop of the armature to the motor terminals via the brushes.

As Figure 26 shows:

- Two alternating-current (ac) voltages E_1 and E_2 are generated, one across each wire loop.
- However, the voltage E_3 at the motor terminals always has the same polarity. This voltage consists of four pulses per rotation of the armature instead of only two pulses per rotation. Consequently, the fluctuation of the generated dc voltage caused by the pulsating effect is reduced.

The higher the number of wire loops at the armature, the higher the number of segments on the commutator and thus, the higher the number of pulses per rotation and the lower the voltage fluctuation at the dc motor terminals.

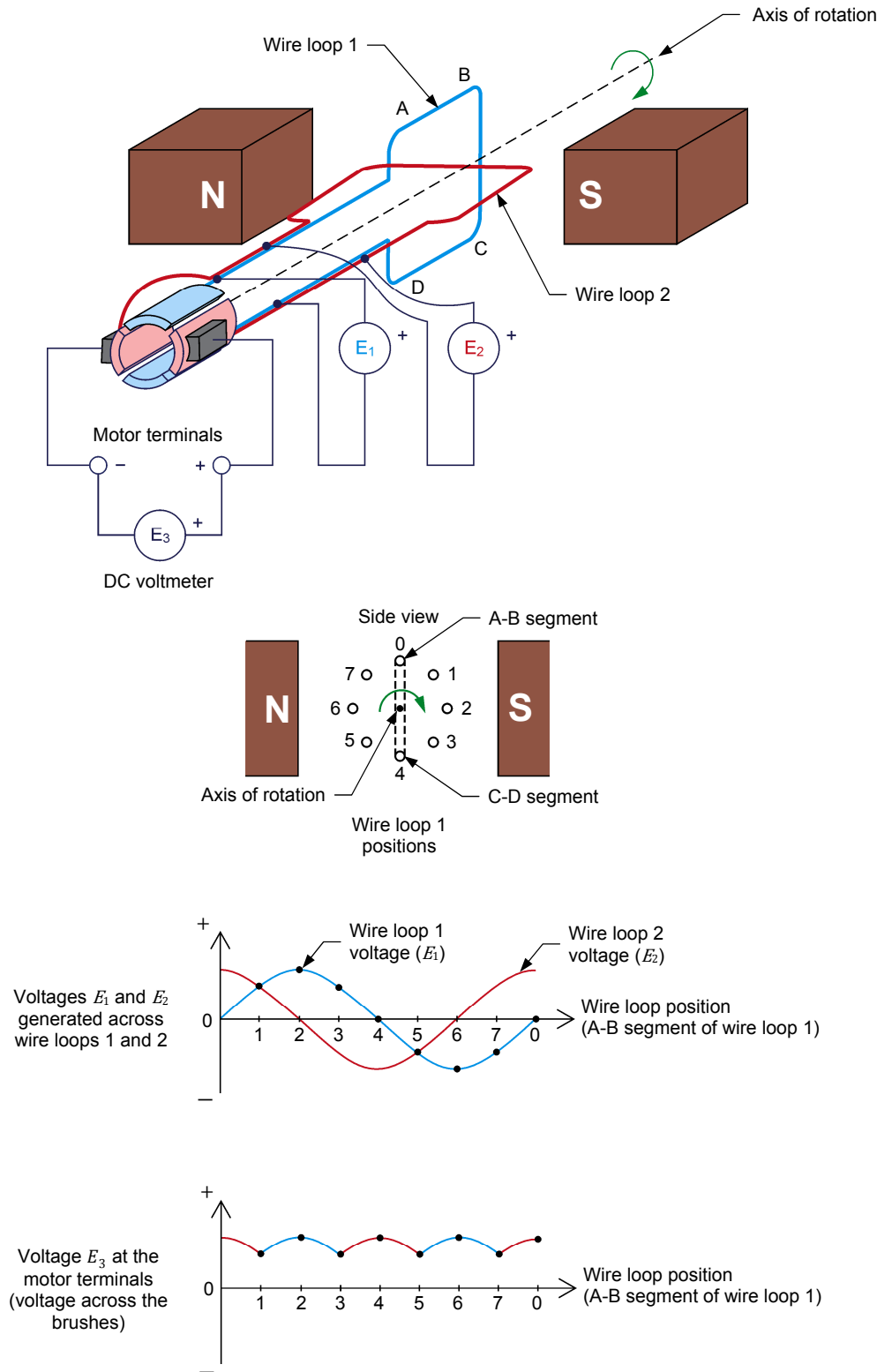

Figure 26. Adding loops of wire to the dc motor armature increases the value of the generated dc voltage and reduces the voltage fluctuation due to the pulsating effect.

Characteristic of the generated voltage as a function of the rotation speed

Figure 27 shows the generated voltage-versus-speed characteristic of a permanent magnet dc motor operating as a generator. The generated voltage is proportional to the rotation speed of the armature. This is because the higher the rotation speed of the armature, the higher the rate of change of the magnetic flux ($\frac{\Delta\Phi}{\Delta t}$) in the rotor wire loops, and thus, the higher the generated voltage. The polarity of the generated voltage depends on the direction of rotation of the armature. When the armature rotates in the clockwise (CW) direction, the generated voltage is positive. Conversely, when the armature rotates in the counterclockwise (CCW) direction, the generated voltage is negative.



The relationship between the polarity of the generated dc voltage and rotor direction of rotation is arbitrarily selected. Thus, the polarity of the generated dc voltage can be considered to be negative when the rotor rotates clockwise and positive when the rotor rotates counterclockwise.

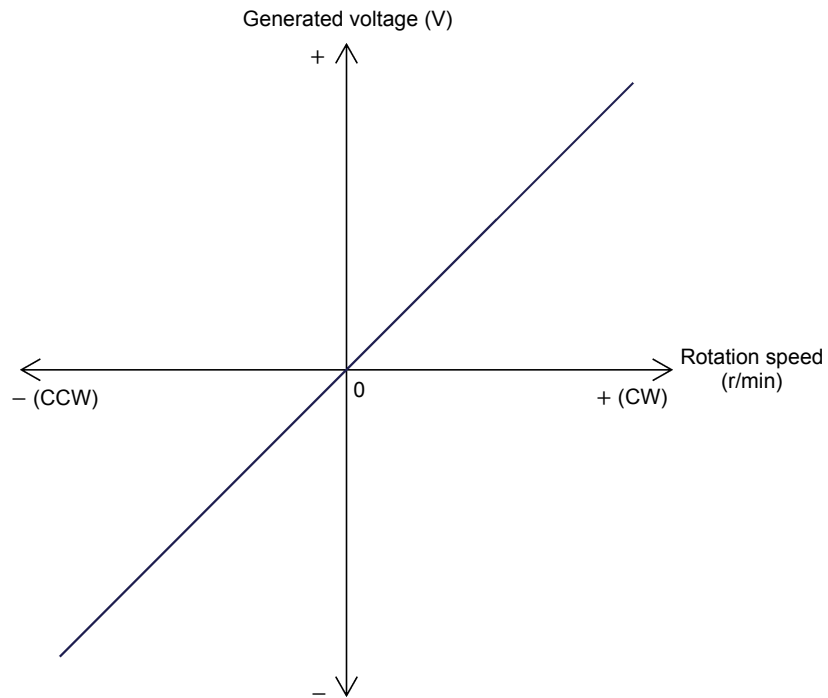

Figure 27. Generated voltage versus speed characteristic of a permanent magnet dc motor operating as a generator.

Torque opposing rotation in a permanent magnet dc motor operating as a generator

Torque is a force used to make an object rotate or, conversely, a force opposing the rotation of an object. This object may be, for example, the rotor of a generator. In that case, torque is applied to the rotor of the generator to make it turn, and, in reaction, the generator produces torque that opposes rotation. Conversely, a torque opposes the rotation of the rotor when a load is applied to the generator.

Figure 28 illustrates the above example using a permanent magnet dc motor operating as a generator. When a load like a resistor is connected to the terminals of a dc motor operating as a generator, current starts to flow in the armature wire loop through the load. This current produces a magnetic field inside the wire loop with a north pole and a south pole, as shown by the red lines of force around the loop in Figure 28. The green lines in this figure show the magnetic field produced by the permanent magnets.

The location of the poles of the magnetic field produced in the wire loop with respect to the poles of the permanent magnets on the motor stator creates forces of **attraction and repulsion** that oppose armature rotation, as Figure 28 shows. The combined effect of these forces is to apply torque to the motor shaft that opposes rotation. The higher the current flowing in the loop, the stronger the magnetic field produced in the loop and the stronger the torque that opposes rotation.

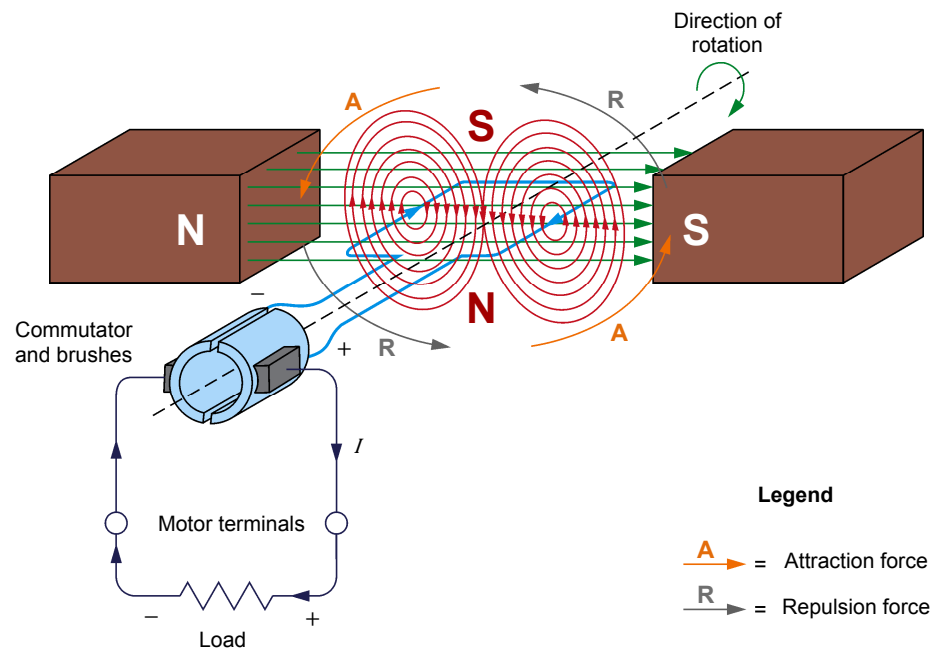

Figure 28. The interaction between the magnetic field produced by the permanent magnets in a dc motor and the magnetic field produced in the armature wire loop when an electric load is connected to the dc motor creates attraction and repulsion forces in the motor that result in torque opposing the armature rotation.

In Figure 28, the magnetic fields produced by the wire loop and the permanent magnets are shown as two separate fields to make the explanation clearer. However, since magnetic lines of force cannot intersect each other, the resulting magnetic field in an actual dc motor operating as a generator resembles that shown in the cross-sectional view of the motor in Figure 29. However, this does not change the end result, i.e., the combined effect of the forces of attraction and repulsion result in a torque that opposes rotation (opposition torque).

Since the opposition torque produced by a permanent magnet dc motor operating as a generator acts in the direction opposite to the direction of rotation of the armature, its polarity is opposite to the polarity of the rotation speed. Thus, when the armature rotates clockwise (i.e., when the polarity of the rotation speed is positive), the polarity of the opposition torque is negative. Conversely, when

the armature rotates counterclockwise (i.e., when the polarity of the rotation speed is negative), the polarity of the generator torque is positive.

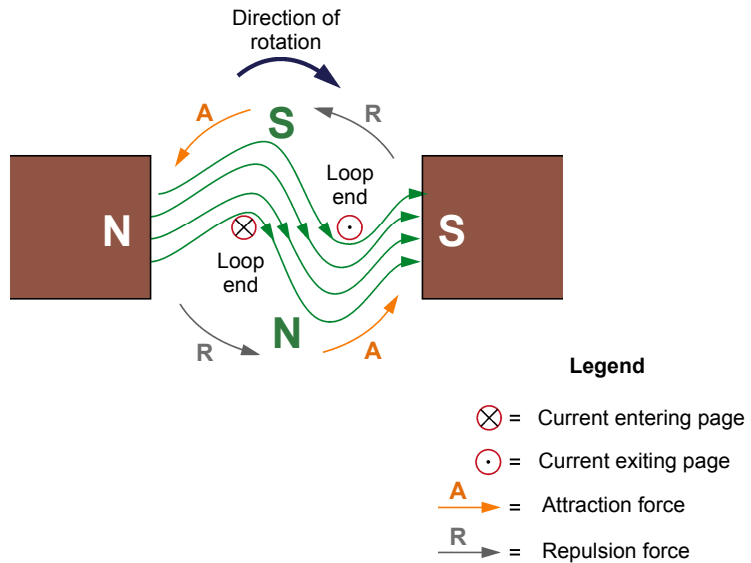

Figure 29. Magnetic field in an actual dc motor operating as a generator.

Opposition torque-versus-current characteristic

Figure 30 shows the opposition torque-versus-load current characteristic of a permanent magnet dc motor operating as a generator. The opposition torque is proportional to the current supplied to the load. Notice that the opposition torque is expressed with a negative polarity to indicate that it opposes armature rotation (the rotation speed is generally considered to be positive).

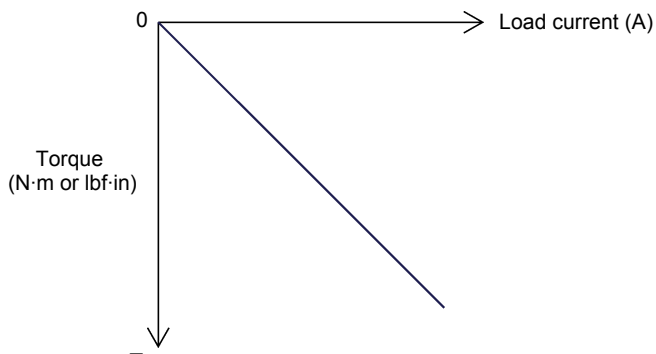

Figure 30. Opposition torque-versus-current characteristic of a permanent magnet dc motor operating as a generator.

PROCEDURE OUTLINE

The Procedure is divided into the following sections:

- Electromagnetic induction phenomenon
- Opposition to rotation
- Voltage-versus-speed characteristic of a permanent magnet dc motor operating as a generator
 - Clockwise rotation
 - Counterclockwise rotation
- Torque-versus-current characteristic of a permanent magnet dc motor operating as a generator

PROCEDURE



High voltages are present in this laboratory exercise. Do not make or modify any banana jack connections with the power on unless otherwise specified.

Electromagnetic induction phenomenon

In this section of the exercise, you will connect a dc voltmeter across the motor terminals and observe the voltage developed across these terminals when the motor shaft is rotated manually.

1. Place the **Permanent Magnet DC Motor** on your work surface. Connect a dc voltmeter to the terminals of the **Permanent Magnet DC Motor**. The red motor terminal is the positive terminal.
2. Make the shaft of the **Permanent Magnet DC Motor** rotate clockwise with your hands. Notice that a dc voltage of positive polarity appears across the motor terminals. Explain why a dc voltage is developed at the motor terminals when its shaft is rotated.

3. Make the shaft of the **Permanent Magnet DC Motor** rotate counterclockwise with your hands. Does a dc voltage of negative polarity appear across the motor terminals? Why?

4. Disconnect the dc voltmeter from the **Permanent Magnet DC Motor**.

Opposition to rotation

In this section, you will observe the opposition to rotation of the Permanent Magnet DC Motor when the terminals of the motor are not short-circuited and when they are.

5. Make the shaft of the **Permanent Magnet DC Motor** rotate with your hands. Notice that it is easy to make the motor shaft rotate. Explain why.

6. Short-circuit the two terminals of the **Permanent Magnet DC Motor** with a lead.

Make the motor shaft rotate clockwise with your hands, then make it rotate counterclockwise. Notice that it is less easy to make the motor shaft rotate when the motor terminals are short-circuited. Explain why.

7. Remove the lead short-circuiting the motor terminals.

Voltage-versus-speed characteristic of a permanent magnet dc motor operating as a generator

In this section, you will use a prime mover to drive the Permanent Magnet DC Motor and make it operate as a generator. You will vary the rotation speed of the prime mover by steps and measure the dc voltage generated across the motor terminals.

8. Refer to the Equipment Utilization Chart in Appendix A to obtain the list of equipment required to perform the rest of this exercise.

Install the equipment in the **Workstation**.

Mechanically couple the **Four-Quadrant Dynamometer/Power Supply** to the **Permanent Magnet DC Motor** using a timing belt.



Before coupling rotating machines, make absolutely sure that power is turned off to prevent any machine from starting inadvertently.

9. Make sure that the main power switch on the **Four-Quadrant Dynamometer/Power Supply** is set to the **O** (off) position, then connect its **Power Input** to an ac power wall outlet.

Connect the **Power Input** of the **Data Acquisition and Control Interface (DACI)** to a 24 V ac power supply. Turn the 24 V ac power supply on.

10. Connect the USB port of the **Four-Quadrant Dynamometer/Power Supply** to a USB port of the host computer.

Connect the USB port of the **Data Acquisition and Control Interface** to a USB port of the host computer.

11. On the **Four-Quadrant Dynamometer/Power Supply**, set the **Operating Mode** switch to **Dynamometer**. This setting allows the **Four-Quadrant Dynamometer/Power Supply** to operate as a prime mover, a brake, or both, depending on the selected function.

Turn the **Four-Quadrant Dynamometer/Power Supply** on by setting the main power switch to **I** (on).

12. Turn the host computer on, then start the **LVDAC-EMS** software.

In the **LVDAC-EMS Start-Up** window, make sure that the **Data Acquisition and Control Interface** and the **Four-Quadrant Dynamometer/Power Supply** are detected. Make sure that the **Computer-Based Instrumentation** function for the **Data Acquisition and Control Interface** is available. Also, select the network voltage and frequency that correspond to the voltage and frequency of your local ac power network, then click the **OK** button to close the **LVDAC-EMS Start-Up** window.

13. Connect the equipment as shown in Figure 31. In this circuit, the **Permanent Magnet DC Motor** is driven, via a belt, by the motor in the **Four-Quadrant Dynamometer/Power Supply**. **E1** is a voltage input of the **Data Acquisition and Control Interface**.



Appendix C shows in more detail the equipment and the connections required for the circuit diagram below.

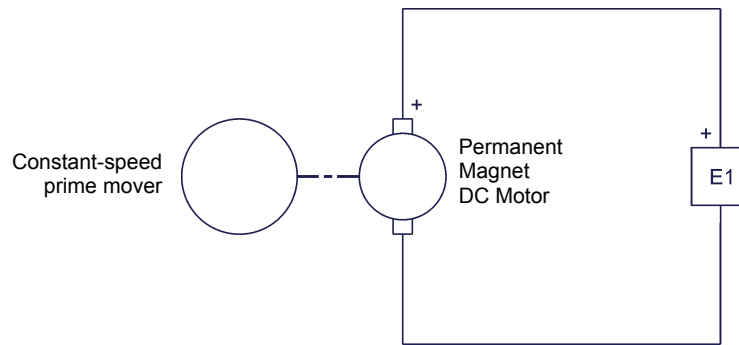

Figure 31. Setup used to plot the voltage-versus-speed characteristic of a permanent magnet dc motor operating as a generator.

Clockwise rotation

14. In **LVDAC-EMS**, open the **Four-Quadrant Dynamometer/Power Supply** window, then make the following settings:

- Set the **Function** parameter to **CW Constant-Speed Prime Mover/Brake**. This setting makes the **Four-Quadrant Dynamometer/Power Supply** operate as a clockwise prime mover/brake with a speed setting corresponding to the **Speed** parameter.
- Set the **Pulley Ratio** parameter to 24:12. The first and second numbers in this parameter specify the number of teeth on the pulley of the **Four-Quadrant Dynamometer/Power Supply** and the number of teeth on the pulley of the machine under test (i.e., the **Permanent Magnet DC Motor**), respectively.
- Make sure that the **Speed Control** parameter is set to **Knob**. This allows the speed of the clockwise prime mover/brake to be controlled manually.
- Set the **Speed** parameter (i.e., the speed command) to 1000 r/min by entering 1000 in the field next to this parameter. Notice that the speed command is the targeted speed at the shaft of the machine coupled to the prime mover, i.e., the speed of the **Permanent Magnet DC Motor** in the present case.



*The speed command can also be set by using the **Speed** control knob in the **Four-Quadrant Dynamometer/Power Supply** window.*

15. In **LVDAC-EMS**, start the **Metering** application. Set meter **E1** as a dc voltmeter.

Click the **Continuous Refresh** button to enable continuous refresh of the values indicated by the various meters in the **Metering** application.

16. In the **Four-Quadrant Dynamometer/Power Supply** window, start the **CW Constant-Speed Prime Mover/Brake** by clicking the **Start/Stop** button or by setting the **Status** parameter to **Started**.

Observe that the prime mover starts to rotate, thereby driving the shaft of the **Permanent Magnet DC Motor**.

The **Speed** meter in the **Four-Quadrant Dynamometer/Power Supply** window indicates the rotation speed of the **Permanent Magnet DC Motor**. Is this speed approximately equal to the value of the **Speed** parameter (1000 r/min)?

Yes No

Meter **E1** in the **Metering** window indicates the dc voltage generated across the **Permanent Magnet DC Motor** terminals. Record this voltage below.

DC voltage generated = _____ V

17. In **LVDAC-EMS**, open the **Data Table** window. Set the **Data Table** to record the rotation speed of the **Permanent Magnet DC Motor** (indicated by the **Speed** meter in the **Four-Quadrant Dynamometer/Power Supply**) and the dc voltage generated across the motor terminals (indicated by meter **E1** in the **Metering** window).



To select the parameters to be recorded in the **Data Table**, click the **Options** menu of the **Data Table** and then click **Record Settings**. In the **Settings list**, select **Four-Quadrant Dynamometer/Power Supply**, then check the **Speed** box. In the **Settings list**, select **Metering**, then check the box of meter **E1**. Click **OK** to close the **Record Settings** box.

18. Make the rotation speed of the **Permanent Magnet DC Motor** vary from 0 to 4000 r/min in steps of 500 r/min by adjusting the **Speed** parameter. For each speed setting, record the motor rotation speed (indicated by the **Speed** meter) and the dc voltage (meter **E1**) generated across the motor terminals in the **Data Table** by clicking the **Record Data** button in this table.

Counterclockwise rotation

19. In the **Four-Quadrant Dynamometer/Power Supply** window, stop the **CW Constant-Speed Prime Mover/Brake** by clicking the **Start/Stop** button or by setting the **Status** parameter to **Stopped**. Then, make the following settings:
- Set the **Function** parameter to **CCW Constant-Speed Prime Mover/Brake**. This setting makes the **Four-Quadrant Dynamometer/Power Supply** operate as a counterclockwise prime mover/brake with a speed setting corresponding to the **Speed** parameter.
 - Set the **Pulley Ratio** parameter to 24:12.
 - Make sure that the **Speed Control** parameter is set to **Knob**.

- Set the *Speed* parameter to 0 r/min.
 - Start the *CCW Constant-Speed Prime Mover/Brake* by clicking the *Start/Stop* button or by setting the *Status* parameter to *Started*.
- 20.** Make the rotation speed of the *Permanent Magnet DC Motor* vary from 0 to -4000 r/min in steps of about -500 r/min by adjusting the *Speed* parameter in the *Four-Quadrant Dynamometer/Power Supply* window. For each speed setting, record the motor rotation speed and the dc voltage (meter *E1*) generated across the motor terminals in the *Data Table*.
- 21.** In the *Four-Quadrant Dynamometer/Power Supply* window, stop the *CCW Constant-Speed Prime Mover/Brake* by clicking the *Start/Stop* button or by setting the *Status* parameter to *Stopped*.
- 22.** From the results recorded in the *Data Table*, plot the curve of the dc voltage generated across the motor terminals versus the motor rotation speed.

According to the obtained curve, is the voltage generated across a permanent magnet dc motor operating as a generator proportional to the rotation speed?

- Yes No

Does the polarity of the generated dc voltage depend on the direction of rotation, thereby confirming what has been observed at the beginning of this exercise when you turned the motor shaft manually and measured the generated voltage with a dc voltmeter? Explain.

Save the data recorded in the *Data Table*, then close this table.

Torque-versus-current characteristic of a permanent magnet dc motor operating as a generator

In this section, you will use a prime mover to drive the Permanent Magnet DC Motor and make it operate as a generator. You will vary the opposition torque developed at the motor shaft and measure the current flowing through the generator armature.

- 23.** Connect the equipment as shown in Figure 32. Use the high-current (40 A) terminal of current input *I1* on the *Data Acquisition and Control Interface*.

In the **Data Acquisition and Control Settings** window of LVDAC-EMS, set the **Range** of current input **I1** to **High**.



Appendix C shows in more detail the equipment and the connections required for the circuit diagram.

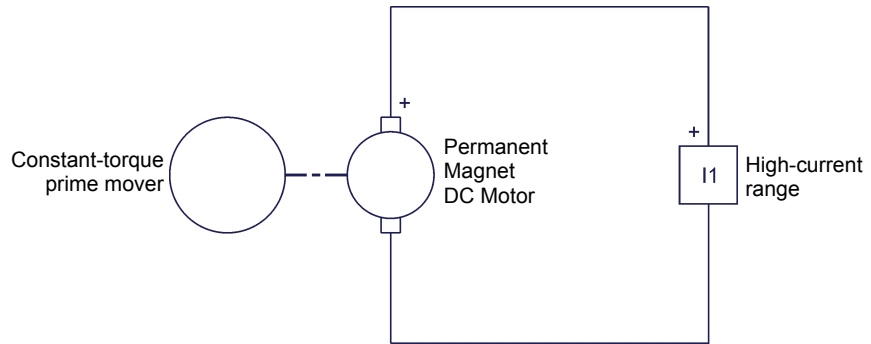

Figure 32. Setup used to plot the torque-versus-current characteristic of a permanent magnet dc motor operating as a generator.

24. In the **Four-Quadrant Dynamometer/Power Supply** window, make the following settings:

- Set the **Function** parameter to **Positive Constant-Torque Prime Mover/Brake**. This setting makes the **Four-Quadrant Dynamometer/Power Supply** operate as a constant-torque prime mover/brake with a torque setting corresponding to the **Torque** parameter.
- Set the **Pulley Ratio** parameter to 24:12.
- Set the **Torque** parameter to 0.3 N·m (2.7 lbf in) by entering 0.3 (2.7) in the field next to this parameter.

25. In the **Metering** window of LVDAC-EMS, set meter **I1** to display dc values. Ensure the continuous refresh mode of the meters is enabled.

26. In the **Four-Quadrant Dynamometer/Power Supply** window, start the **Positive Constant-Torque Prime Mover/Brake** by setting the Status parameter to **Started** or by clicking the **Start/Stop** button.

Observe that the prime mover starts to rotate clockwise, thereby driving the shaft of the **Permanent Magnet DC Motor**.

The *Speed* and *Torque* meters in the *Four-Quadrant Dynamometer/Power Supply* indicate the rotation speed and torque at the shaft of the *Permanent Magnet DC Motor*. Notice that the torque is of negative polarity, i.e., opposite to the polarity (positive) of the rotation speed. This is because the *Permanent Magnet DC Motor* is operating as a generator. Is the torque (absolute value) indicated by the *Torque* meter approximately equal to the value of the *Torque* parameter?

Yes No

Meter *I1* in the *Metering* window indicates the dc current flowing in the armature of the *Permanent Magnet DC Motor*. Record this current below.

DC current flowing in the motor = _____ A

27. In *LVDAC-EMS*, open the *Data Table* and make the settings required to record the torque developed the shaft of this motor (indicated by the *Torque* meter in the *Four-Quadrant Dynamometer/Power Supply*) and the dc current flowing in the armature of the *Permanent Magnet DC Motor* (indicated by meter *I1* in the *Metering* window).



*To select the parameters to be recorded in the *Data Table*, click the *Options* menu of the *Data Table* and then click *Record Settings*. In the *Settings* list, select *Four-Quadrant Dynamometer/Power Supply*, then check the *Torque* box. In the *Settings* list, select *Metering*, then check the box of meter *I1*. Click *OK* to close the *Record Settings* box.*

28. Make the torque developed at the shaft of the *Permanent Magnet DC Motor* vary from 0 to -0.7 N·m (or from 0 to -6.0 lbf·in) in steps of -0.1 N·m (or -1 lbf·in) by adjusting the *Torque* parameter. For each torque setting, record the current flowing in the armature of the dc motor (meter *I1*) and the torque developed at the motor shaft (indicated by the *Torque* meter) in the *Data Table*.

CAUTION

Since the output of the *Permanent Magnet DC Motor* is short circuited by current input *I1*, high currents can flow in the motor at low torques and rotation speeds. Make sure not to exceed the current rating of the *Permanent Magnet DC Motor*. Perform the remainder of this manipulation in less than 5 minutes.

29. In the *Four-Quadrant Dynamometer/Power Supply* window, stop the *Positive Constant-Torque Prime Mover/Brake*.
30. From the results recorded in the *Data Table*, plot a curve of the torque developed at the motor shaft as a function of the current flowing in the armature of the dc motor.

According to the obtained curve, is the torque developed at the shaft of a permanent magnet dc motor operating as a generator proportional to the current flowing in the motor armature?

- Yes No

- 31.** Save the data recorded in the [Data Table](#), then close this table. Turn the [Four-Quadrant Dynamometer/Power Supply](#) off by setting the main power switch to **O** (off). Close the [LVDAC-EMS](#) software. Disconnect all leads and return them to their storage location.

CONCLUSION

In this exercise, you familiarized yourself with a permanent magnet dc motor. You learned that this motor consists of a rotor (armature) made of several loops of wire, and a stator made of permanent magnets that produce a fixed magnetic field. When the rotor is rotated by a prime mover, it cuts the lines of force of the stator magnetic field, which produces a dc voltage across the motor terminals: the dc motor operates as a dc generator. The magnitude of the generated voltage is proportional to the rotation speed, while the polarity of this voltage depends on the direction of rotation. For instance, when the rotor rotates clockwise, the dc voltage is positive, and vice-versa. You learned that when a load is connected across the motor terminals, a force (torque) opposing rotor rotation is produced. This torque is in the direction opposite to the direction of rotation. The higher the current supplied to the load, the stronger the torque opposing rotation.

REVIEW QUESTIONS

1. By referring to Figure 21, describe the construction of a simple permanent magnet dc motor.

2. By referring to Figure 24, describe the operation of a simple permanent magnet dc motor used as a generator. Explain how an alternating-current (ac) voltage is induced across the armature wire loop, and why this voltage is unipolar (i.e., why it always has the same polarity) at the motor terminals.

3. What effect does increasing the number of wire loops and commutator segments have on the voltage generated by a permanent magnet dc motor operating as a generator? Explain.

4. Describe the relationship between the voltage generated by a dc motor operating as a generator as a function of the armature rotation speed. When is the generated voltage of positive polarity? When is this voltage of negative polarity?

5. Explain why a force (torque) opposes the rotation of a dc motor operating as a generator when an electrical load like a resistor is connected to the dc motor terminals. When is this force of positive polarity? When is this force of negative polarity?

Permanent Magnet DC Motor Operating as a Motor

EXERCISE OBJECTIVE When you have completed this exercise, you will be familiar with the operation of permanent magnet dc motors used as motors.

DISCUSSION OUTLINE The Discussion of this exercise covers the following points:

- Operation of a permanent magnet dc motor as a motor
- Magnetic field produced in the armature
- Armature rotation resulting from the interaction between the magnetic fields of the armature and permanent magnets
- Equivalent diagram of a permanent magnet dc motor

DISCUSSION

Operation of a permanent magnet dc motor as a motor

Figure 33 shows a diagram of a simple permanent magnet dc motor with two wire loops at the armature. When a dc power source is connected to the motor terminals, current flows in the wire loops of the armature via the brushes, and a magnetic field is produced in the wire loops. The wire loops thus act as electromagnets. The interaction between the magnetic field produced in the armature wire loops and the magnetic field produced by the stator permanent magnets creates attraction and repulsion forces that make the armature rotate. This is explained in detail in the next sections.

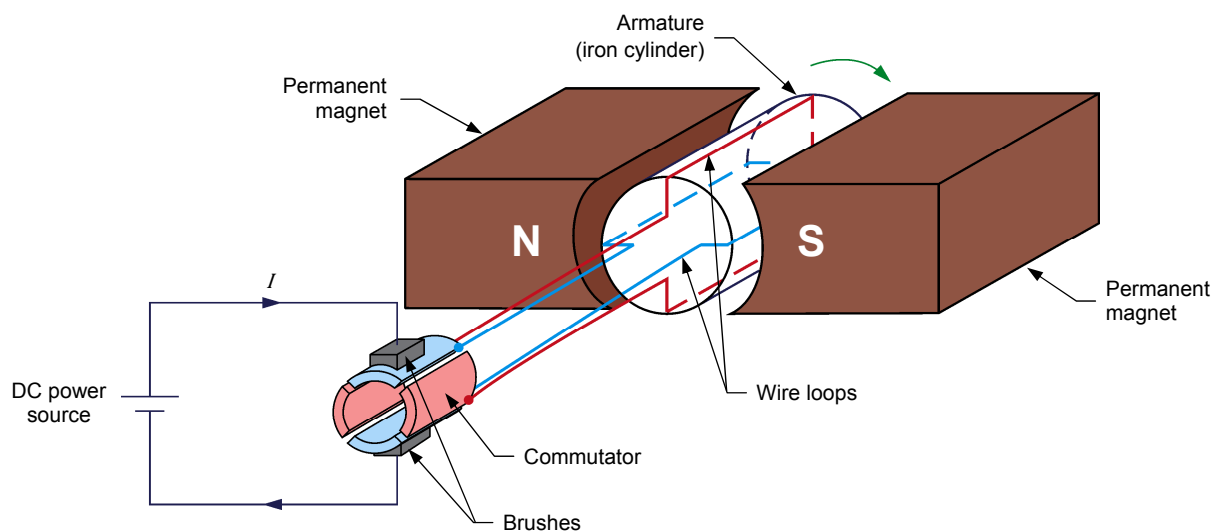

Figure 33. Construction of a simple permanent magnet dc motor.

Magnetic field produced in the armature

Figure 34 and Figure 35 show what happens to the polarity of the magnetic field produced in the armature wire loops when the rotor of the simple permanent magnet dc motor of Figure 33 rotates. In Figure 34a, the brushes make contact with commutator segments A and B. Therefore, current flows from the dc power source to wire loop A-B via the brushes. No current flows in wire loop C-D. This creates an electromagnet A-B with north and south poles, as shown in Figure 34a. When the rotor is rotated clockwise a little as in Figure 34b, current still flows in wire loop A-B, and the north and south poles of the electromagnet are rotated clockwise.

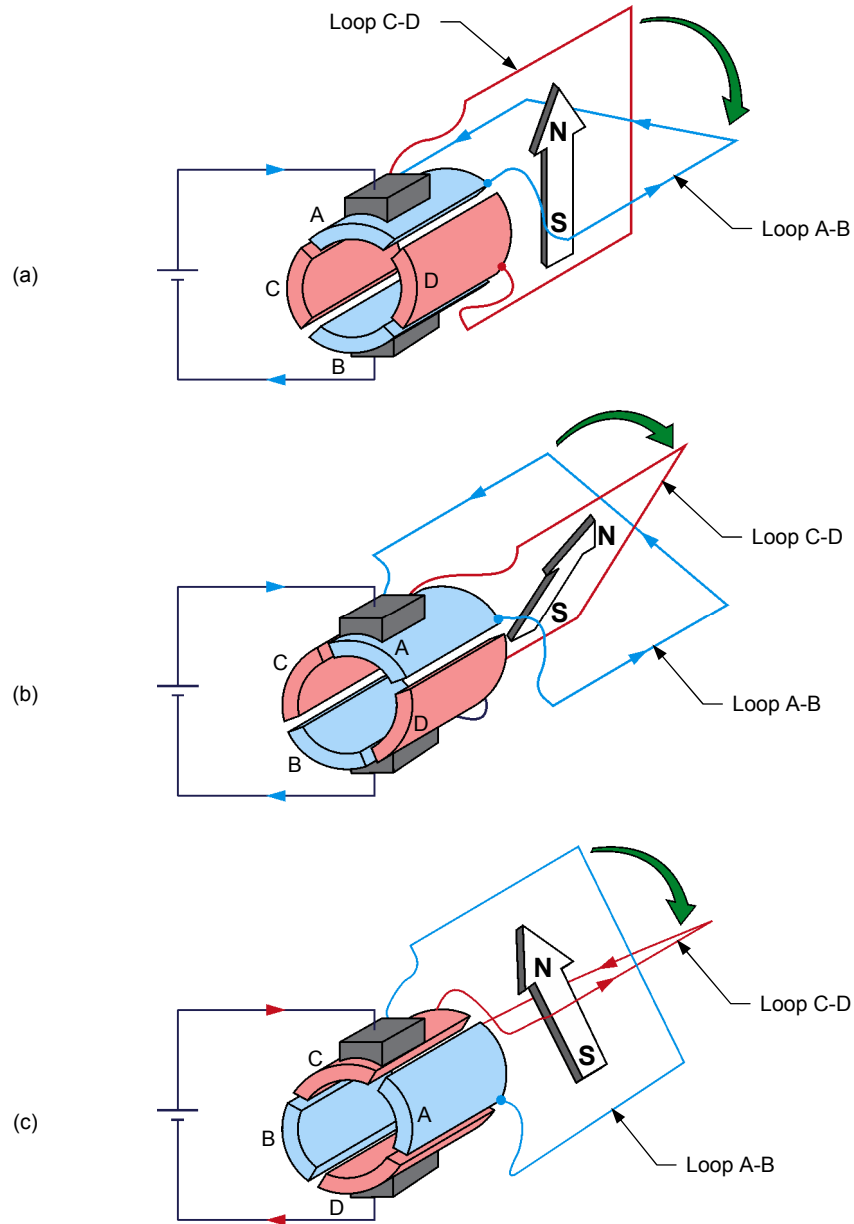

Figure 34. Magnetic field produced at the armature when the rotor rotates clockwise (part I).

As the rotor continues to rotate clockwise, the commutator slots pass by the brushes and a commutation occurs, i.e., the brushes stop making contact with commutator segments A and B and make contact with commutator segments C and D instead, as shown in Figure 34c. Consequently, current stops flowing in wire loop A-B and starts to flow in wire loop C-D. This creates an electromagnet C-D with north and south poles, as shown in Figure 34c.

A comparison of Figure 34b and Figure 34c shows that, at commutation, the north and south poles of the electromagnet are rotated 90° counterclockwise. As the rotor continues to rotate clockwise, the same phenomenon repeats every 90° rotation (i.e., at every commutation), as shown in Figure 35.

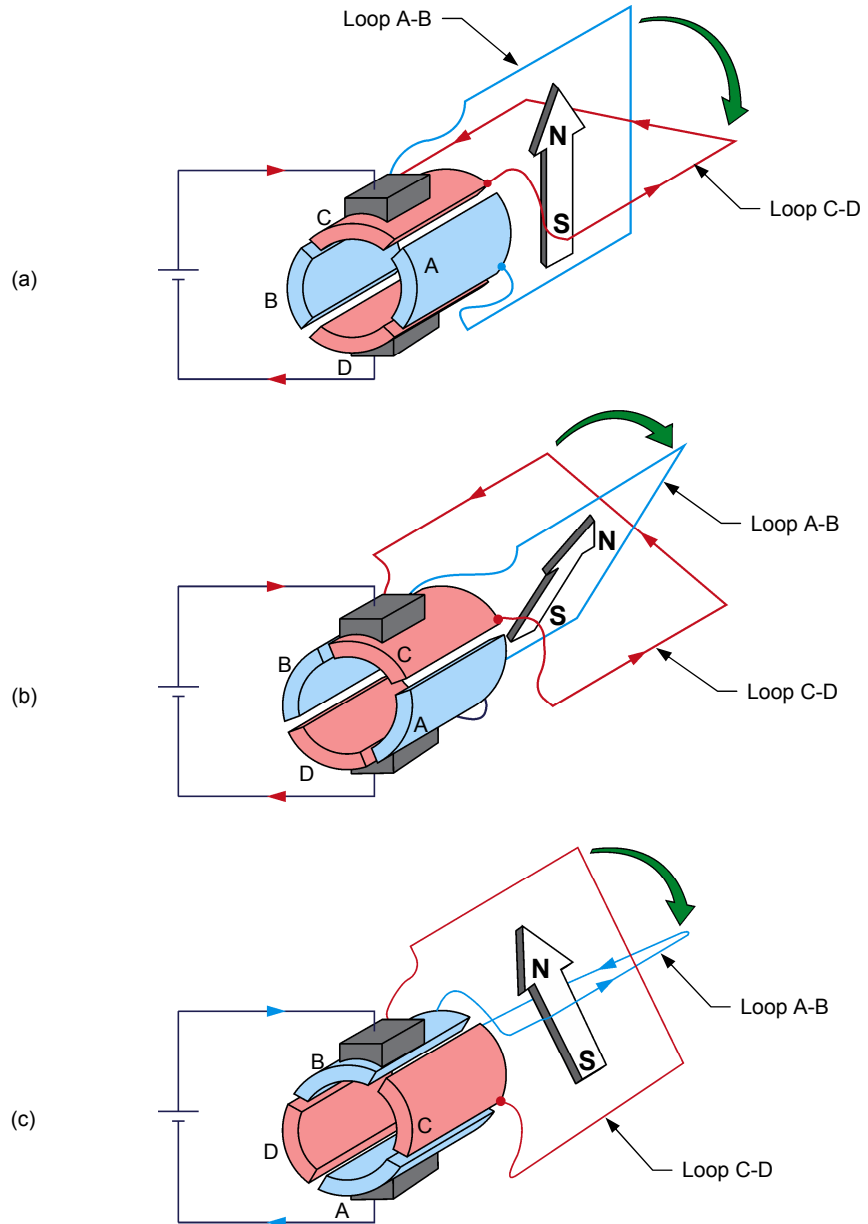

Figure 35. Magnetic field produced at the armature when the rotor rotates clockwise (part II).

In summary, as the rotor rotates, the north and south poles of the electromagnet go back and forth (oscillate) over a 90° angle, as Figure 36 shows. In other words, the north and south poles can be considered as stationary, i.e., they do not rotate as the rotor rotates. This is equivalent to having an electromagnet in the rotor that rotates at the same speed as the rotor, but in the opposite direction.

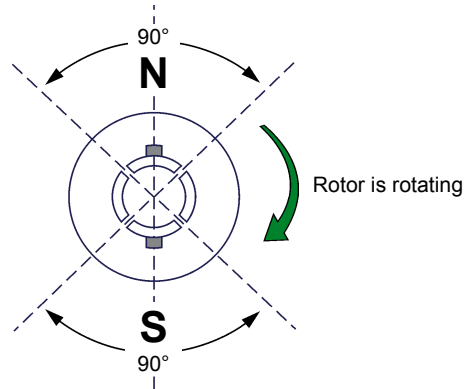

Figure 36. The north and south poles of the electromagnet at the armature oscillate around a fixed position.

The higher the number of segments on the commutator, the lower the angle of rotation between each commutation, and thus, the lower the angle over which the north and south poles of the electromagnet oscillate. For example, if the commutator shown in Figure 33, Figure 34, and Figure 35 were having 32 segments instead of 4, the north and south poles would oscillate over an angle of only 11.25° instead of 90° .

Armature rotation resulting from the interaction between the magnetic fields of the armature and permanent magnets

The rotor discussed in the previous section is placed within permanent magnets in a permanent magnet dc motor, as shown in Figure 37. This causes the magnetic field produced by the armature electromagnet to interact with the magnetic field of the permanent magnets. Consequently, the poles of opposite polarities attract each other (in order to align), while the poles of the same polarity repel each other, so the rotor starts to rotate (clockwise in the present case). Once the rotor has rotated by a certain angle (90° in the present case), a commutation occurs, and the north and south poles of the armature electromagnet instantly return to their initial location. Once again, the poles of opposite polarities attract each other (in order to align), while the poles of the same polarity repel each other, so the rotor continues to rotate in the same direction. Once the rotor has rotated by a certain angle (90° in the present case), another commutation occurs and the north and south poles of the armature electromagnet instantly return to their initial location once again. This cycle repeats over and over. The forces resulting from the interaction of the magnetic field produced by the armature electromagnet and the magnetic field of the permanent magnets always act in the same direction (clockwise in the present case), and the rotor rotates continually. Thus, a rotating machine converting electrical energy into mechanical energy, i.e., an electric motor, is achieved.

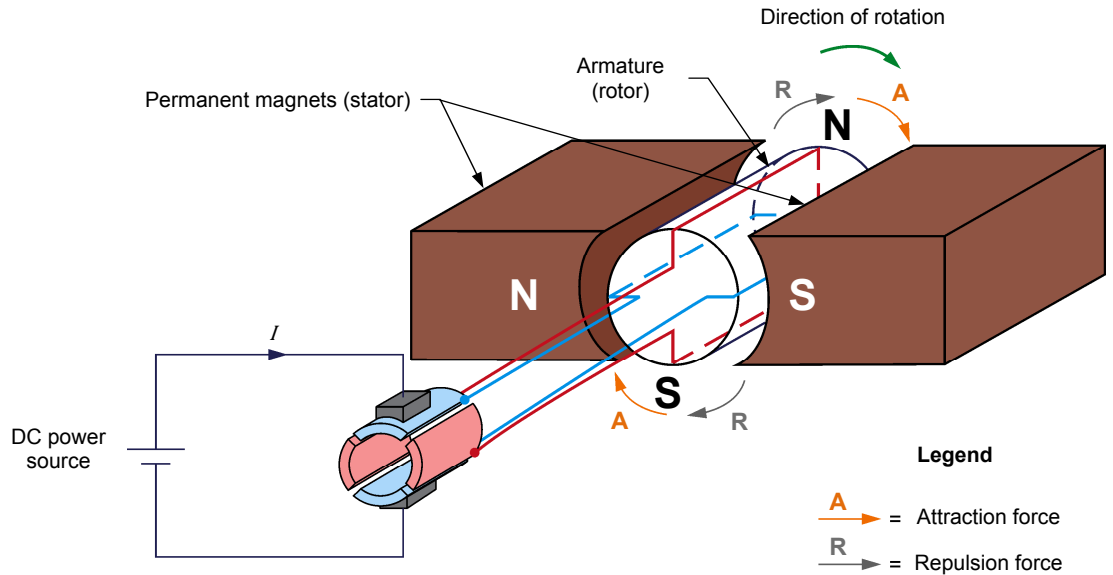

Figure 37. Clockwise rotation resulting from the interaction between the magnetic field produced by the armature electromagnet and the magnetic field of the permanent magnets.

The direction of rotation of the rotor depends on the polarity of the voltage applied to the brushes. When the dc power source connections are reversed, as shown in Figure 38, the polarity of the voltage applied to the brushes is reversed. This reverses the direction of the current flowing in the armature wire loops, and thus, the location of the north and south poles of the magnetic field produced by the armature electromagnet. Consequently, this reverses the direction of the forces resulting from the interaction of the magnetic field produced by the armature electromagnet and the magnetic field of the permanent magnets, thereby reversing the armature's direction of rotation.

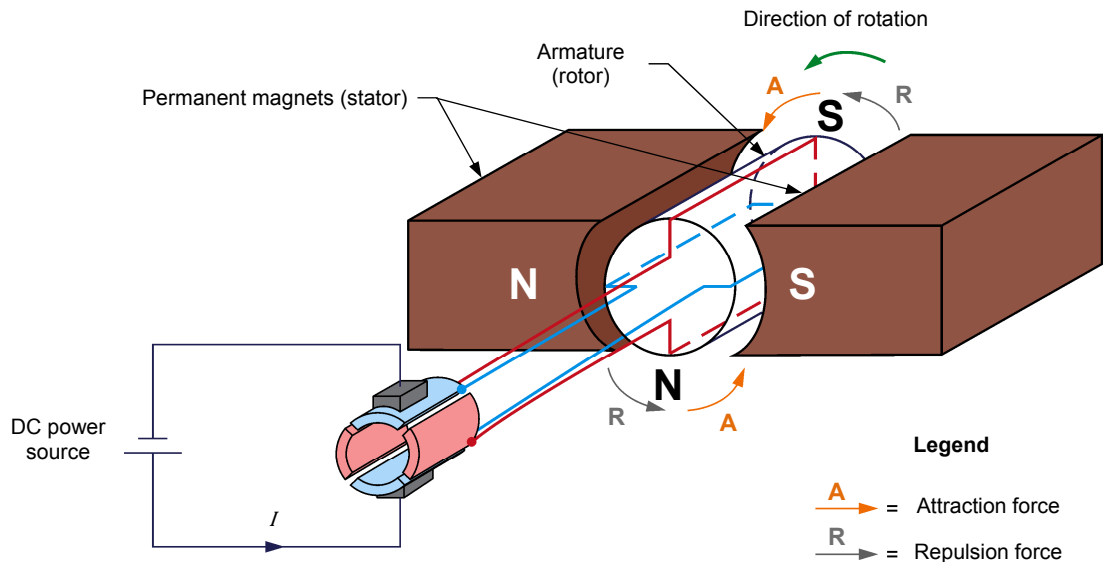

Figure 38. When the polarity of the voltage applied to the brushes is reversed, the direction of rotation of the armature is also reversed.

Equivalent diagram of a permanent magnet dc motor

When dc voltage is applied to a permanent magnet dc motor, it starts to rotate, as was explained in the previous section. Since the armature wire loops are rotating in the magnetic field produced by the permanent magnets, a voltage is induced at the armature, as when the motor operates as a generator. In the present case (i.e., when speaking of a motor), the voltage induced across the armature is due to the **counter-electromotive force (CEMF)**, and is commonly represented by the following variable: E_{CEMF} .

Figure 39 shows the equivalent diagram of a permanent magnet dc motor.

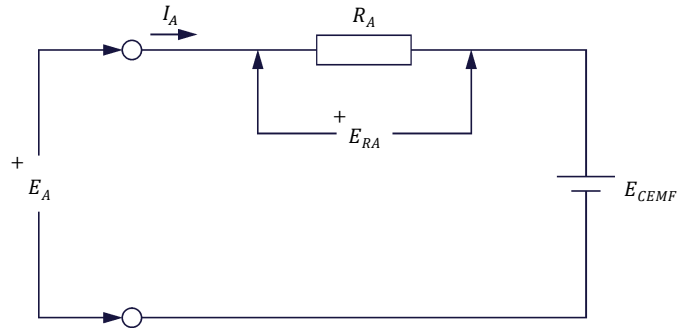

Figure 39. Equivalent diagram of a permanent magnet dc motor.

In this circuit, E_A is the voltage applied to the motor brushes, I_A is the current flowing in the armature through the brushes, and R_A is the total resistance of the wire loops at the armature. Note that E_A , I_A , and R_A are usually referred to as the armature voltage, current, and resistance, respectively. E_{RA} is the voltage drop across the armature resistor. The dc source E_{CEMF} in the equivalent diagram represents the voltage generated at the armature when the motor rotates, i.e., the voltage due to the counter-electromotive force (CEMF). Voltage E_{CEMF} is proportional to the motor speed. Notice that the polarity of voltage E_{CEMF} is such that it opposes the voltage E_A applied to the armature, thereby limiting the armature current I_A . Although not indicated in the equivalent diagram of Figure 39, the motor also develops a torque T proportional to the current I_A flowing in its armature.

The motor operation is governed by the two following equations. Equation (8) states the relationship between the motor speed n and the induced voltage E_{CEMF} . Equation (9) states the relationship between the motor torque T and the armature current I_A .

$$n = K_1 \cdot E_{CEMF} \quad (8)$$

where n is the motor rotation speed (r/min).

K_1 is a constant expressed in $\frac{\text{r/min}}{\text{V}}$.

E_{CEMF} is the voltage induced across the armature (V).

$$T = K_2 \cdot I_A \quad (9)$$

where T is the motor torque (N·m or lbf·in).
 K_2 is a constant expressed in $\frac{\text{N}\cdot\text{m}}{\text{A}}$ or $\frac{\text{lbf}\cdot\text{in}}{\text{A}}$.
 I_A is the armature current (A).

When a voltage E_A is applied to the armature of a permanent magnet dc motor with no mechanical load, the armature current I_A flowing in the equivalent circuit of Figure 39 is constant and of very low value. Consequently, the voltage drop E_{RA} across the armature resistor is so low that it can be neglected, and E_{CEMF} can be considered to be equal to the armature voltage E_A . The relationship between the motor rotation speed n and the armature voltage E_A is therefore a straight line because E_{CEMF} is proportional to the motor rotation speed n . Figure 40 shows this linear relationship. The slope of the straight line equals constant K_1 .

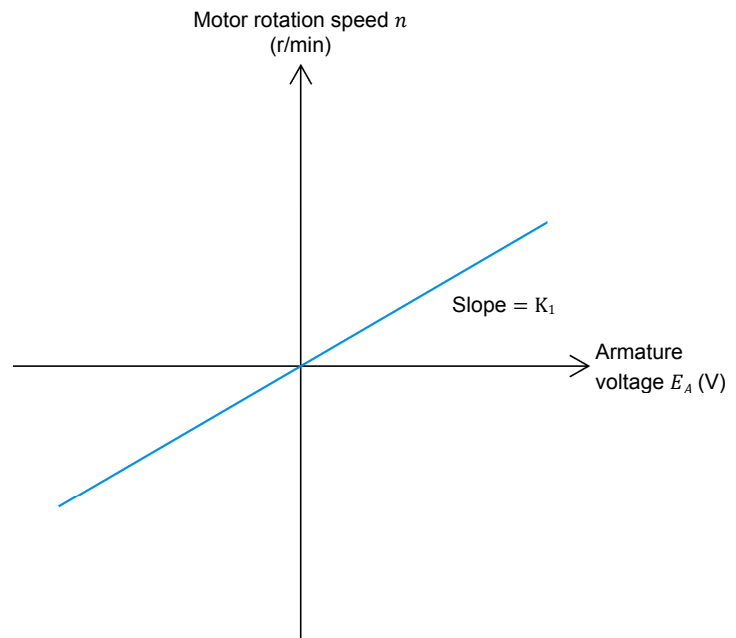

Figure 40. Relationship between the motor rotation speed and the armature voltage.

Since the relationship between the voltage E_A and the motor rotation speed n is linear, a dc motor can be considered a linear voltage-to-speed converter, as Figure 41 shows.

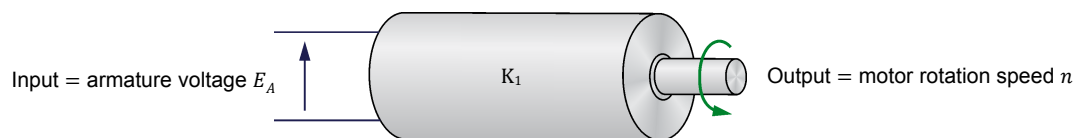

Figure 41. A dc motor can be considered to be a linear voltage-to-speed converter.

The same type of relationship exists between the motor torque T and the armature current I_A . Thus, the relationship between the motor torque T and the armature current I_A is a straight line, as Figure 42 shows. The slope of the straight line equals constant K_2 .

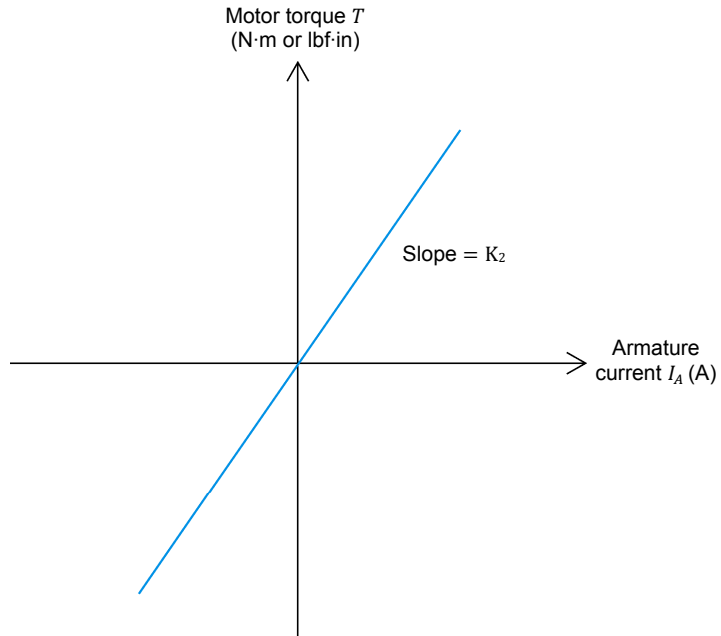

Figure 42. Relationship between the motor torque and the armature current.

Since this relationship is linear, a dc motor can also be considered a linear current-to-torque converter, as Figure 43 shows.

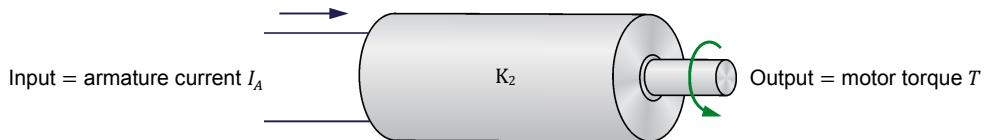

Figure 43. A DC motor can be considered to be a linear current-to-torque converter.

When the motor torque T increases, the armature current increases, and thus, the voltage drop E_{RA} ($R_A \cdot I_A$) across the armature resistor also increases and can no longer be neglected. As a result, the armature voltage E_A is no longer equal to E_{CEMF} , it is rather the sum of E_{CEMF} and E_{RA} , as Equation (10) shows:

$$E_A = E_{CEMF} + E_{RA} \quad (10)$$

Therefore, when a fixed armature voltage E_A is applied to a dc motor, the voltage drop E_{RA} across the armature resistor increases as the motor torque T increases (i.e., as the armature current I_A increases), and thereby, causes E_{CEMF} to decrease. Consequently, the motor rotation speed n decreases because it is

proportional to E_{CEMF} . This is shown in Figure 44, which is a graph of the motor rotation speed n versus the motor torque T for a fixed armature voltage E_A .

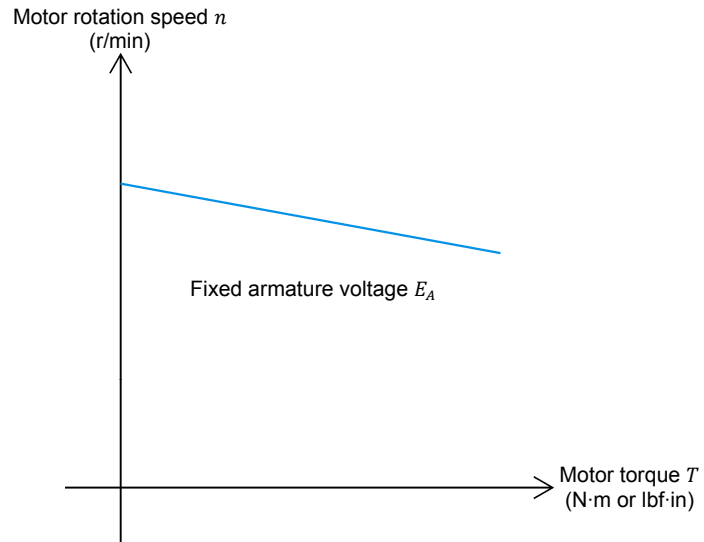

Figure 44. The motor rotation speed decreases as the motor torque increases for a fixed armature voltage E_A .

PROCEDURE OUTLINE

The Procedure is divided into the following sections:

- Setup and connections
- Speed-versus-voltage characteristic of a permanent magnet dc motor operating as a motor
 - Clockwise rotation
 - Counterclockwise rotation
- Torque-versus-current and speed-versus-torque characteristics of a permanent magnet dc motor operating as a motor
 - Clockwise rotation
 - Counterclockwise rotation

PROCEDURE



High voltages are present in this laboratory exercise. Do not make or modify any banana jack connections with the power on unless otherwise specified.



Before performing this exercise, measure the open-circuit voltage across the *Lead-Acid Battery Pack (Model 8802)*, using a multimeter. If the open-circuit voltage is lower than 51.2 V, ask your instructor for assistance as the *Lead-Acid Battery Pack* is probably not fully charged. Appendix D of this manual indicates how to fully charge the *Lead-Acid Battery Pack* before a lab period.

Setup and connections

In this part of the exercise, you will set up and connect the equipment.

1. Refer to the Equipment Utilization Chart in Appendix A to obtain the list of equipment required to perform this exercise.

Install the equipment in the [Workstation](#).

Mechanically couple the [Four-Quadrant Dynamometer/Power Supply](#) to the [Permanent Magnet DC Motor](#) using a timing belt.



Before coupling rotating machines, make absolutely sure that power is turned off to prevent any machine from starting inadvertently.

2. Make sure that the main power switch of the [Four-Quadrant Dynamometer/Power Supply](#) is set to the O (off) position, then connect its [Power Input](#) to an ac power outlet.

Connect the [Power Input](#) of the [Data Acquisition and Control Interface](#) to a 24 V ac power supply. Turn the 24 V ac power supply on.

3. Connect the USB port of the [Four-Quadrant Dynamometer/Power Supply](#) to a USB port of the host computer.

Connect the USB port of the [Data Acquisition and Control Interface](#) to a USB port of the host computer.

4. On the [Four-Quadrant Dynamometer/ Power Supply](#), set the [Operating Mode](#) switch to [Power Supply](#). This setting allows the [Four-Quadrant Dynamometer/Power Supply](#) to operate as a voltage source, current source, battery charger, or battery discharger, depending on the selected function.

Turn the [Four-Quadrant Dynamometer/Power Supply](#) on by setting the main power switch to I (on).

5. Turn the host computer on, then start the [LVDAC-EMS](#) software.

In the [LVDAC-EMS Start-Up](#) window, make sure that the [Data Acquisition and Control Interface](#) and the [Four-Quadrant Dynamometer/Power Supply](#) are detected. Make sure that the [Computer-Based Instrumentation](#) function for the [Data Acquisition and Control Interface](#) is available. Also, select the network voltage and frequency that correspond to the voltage and frequency of your local ac power network, then click the [OK](#) button to close the [LVDAC-EMS Start-Up](#) window.

Speed-versus-voltage characteristic of a permanent magnet dc motor operating as a motor

In this part of the exercise, you will connect a variable-voltage, dc power source to the Permanent Magnet DC Motor terminals to make the motor rotate. You will vary the voltage applied to the motor armature and measure the rotation speed at the motor shaft.

6. Connect the equipment as shown in Figure 45. In this circuit, E_S is a positive dc voltage source implemented with the Four-Quadrant Dynamometer/Power Supply. E_1 and I_1 are voltage and current inputs of the Data Acquisition and Control Interface (DACI). The Permanent Magnet DC Motor is coupled to the Four-Quadrant Dynamometer/Power Supply with a timing belt to allow measurement of the motor rotation speed using the A/B shaft encoder in the Four-Quadrant Dynamometer/Power Supply.



Appendix C shows in more detail the equipment and the connections required for the circuit diagram below.

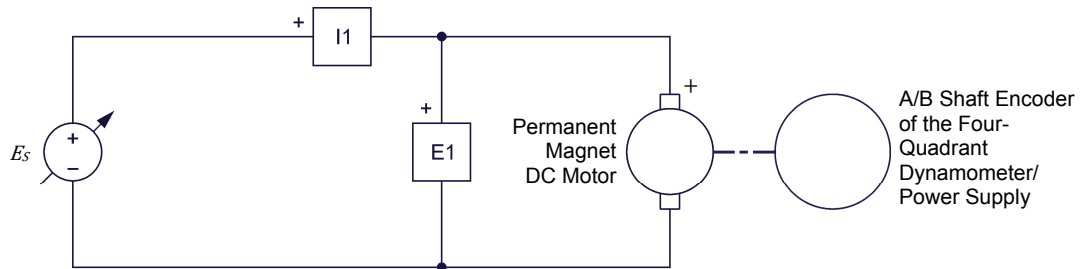

Figure 45. Setup used to plot the speed-versus-voltage characteristic of a permanent magnet dc motor operating as a motor.

7. Connect *Shaft Encoder Outputs A* and *B* of the Four-Quadrant Dynamometer/Power Supply to *Encoder Digital Inputs A* and *B* of the Data Acquisition and Control Interface (DACI), respectively, using 2 mm leads. Also, connect the common (white) terminal of the *Shaft Encoder Outputs* on the Four-Quadrant Dynamometer/Power Supply to one of the two common (white) terminals of the *Digital Inputs* on the DACI using a 2 mm lead. These connections allow measurement of the rotation speed at the shaft of the Four-Quadrant Dynamometer/Power Supply, in order to determine the rotation speed at the shaft of the Permanent Magnet DC Motor.

Clockwise rotation

8. In LVDAC-EMS, open the Four-Quadrant Dynamometer/Power Supply window, then make the following settings:
 - Set the *Function* parameter to *DC Voltage Source*. This setting makes the Four-Quadrant Dynamometer/Power Supply operate as a dc voltage source with a voltage setting corresponding to the *Voltage* parameter.
 - Make sure that the *Voltage Control* parameter is set to *Knob*. This allows the dc source voltage to be controlled manually.

- Set the *Voltage* parameter to 10 V by entering 10 in the field next to this parameter.



The dc source voltage can also be set by using the *Voltage* control knob in the *Four-Quadrant Dynamometer/Power Supply* window.

9. In *LVDAC-EMS*, start the *Metering* application. Set meter *E1* as a dc voltmeter and meter *I1* as a dc ammeter. Also, set another meter to measure rotation speed using the signals provided by *Shaft Encoder Outputs A* and *B* of the *Four-Quadrant Dynamometer/Power Supply* (these outputs feed *Encoder Digital Inputs A* and *B* of the *Data Acquisition and Control Interface*).

Click the *Continuous Refresh* button to enable continuous refresh of the values indicated by the various meters in the *Metering* application.

10. In the *Data Acquisition and Control Settings* window of *LVDAC-EMS*, set the *Digital Input A/B Encoder* parameter to 180 PPR (pulses per revolution). This setting allows the *Speed* meter in the *Metering* window (set in the previous manipulation) to measure the rotation speed of the *Permanent Magnet DC Motor*.



The A/B shaft encoder in the *Four-Quadrant Dynamometer/Power Supply* provides 360 pulses per revolution (PPR). Thus, whenever the shaft of the rotating machine in the *Four-Quadrant Dynamometer/Power Supply* makes one turn, 360 pulses are produced at *Shaft Encoder Outputs A* and *B*. Because the pulley ratio between the *Four-Quadrant Dynamometer/Power Supply* and the *Permanent Magnet DC Motor* is 24:12, the rotating machine in the *Four-Quadrant Dynamometer/Power Supply* rotates half a turn whenever the *Permanent Magnet DC Motor* makes one turn. Consequently, only 180 pulses are produced at *Shaft Encoder Outputs A* and *B* for each revolution of the *Permanent Magnet DC Motor*. Setting the *Digital Input A/B Encoder* parameter to 180 PPR thereby allows direct measurement of the rotation speed of the *Permanent Magnet DC Motor* using the *Speed* meter in the *Metering* window.

11. In the *Four-Quadrant Dynamometer/Power Supply* window, start the *DC Voltage Source* by clicking the *Start/Stop* button or by setting the *Status* parameter to *Started*.

Observe that the *Permanent Magnet DC Motor* starts to rotate, thereby turning the shaft of the *Four-Quadrant Dynamometer/Power Supply*.

Meter *E1* in the *Metering* window indicates the armature voltage of the *Permanent Magnet DC Motor*. Record this voltage below.

Armature voltage = _____ V

Meter *Encoder AB* in the *Metering* window indicates the rotation speed of the *Permanent Magnet DC Motor*. Record this rotation speed below.

Rotation speed of the *Permanent Magnet DC Motor* = _____ r/min

12. In LVDAC-EMS, open the **Data Table** window. Set the **Data Table** to record the armature voltage of the **Permanent Magnet DC Motor** (indicated by meter **E1** in the **Metering** window) and the rotation speed of the **Permanent Magnet DC Motor** (indicated by meter **Encoder AB** in the **Metering** window).



To select the parameters to be recorded in the **Data Table**, open the **Record Settings** dialog box then select meter **E1** and meter **Encoder AB**. Click **OK** to close the **Record Settings** dialog box.

13. Make the armature voltage of the **Permanent Magnet DC Motor** vary from 0 to +48 V in about 8 to 10 steps by adjusting the **Voltage** parameter in the **Four-Quadrant Dynamometer/Power Supply** window. For each voltage setting, record the motor armature voltage and the motor rotation speed of the **Permanent Magnet DC Motor** in the **Data Table** by clicking the **Record Data** button in this table.

Counterclockwise rotation

14. In the **Four-Quadrant Dynamometer/Power Supply** window, set the **Voltage** parameter to 0 V to stop the motor.

Make the armature voltage of the **Permanent Magnet DC Motor** vary from 0 to -48 V in about 8 to 10 steps by adjusting the **Voltage** parameter in the **Four-Quadrant Dynamometer/Power Supply** window. For each voltage setting, record the motor armature voltage and the rotation speed of the **Permanent Magnet DC Motor** in the **Data Table** by clicking the **Record Data** button in this table.

15. In the **Four-Quadrant Dynamometer/Power Supply** window, set the **Voltage** parameter to 0 V to stop the motor. Stop the **DC Voltage Source** by clicking the **Start/Stop** button or by setting the **Status** parameter to **Stopped**.

Save the data recorded in the **Data Table**.

16. From the results recorded in the **Data Table**, plot the curve of the rotation speed at the shaft of the **Permanent Magnet DC Motor** as a function of the motor armature voltage.

According to the obtained curve, is the rotation speed of a permanent magnet dc motor operating as a motor proportional to the voltage applied to the motor armature?

Yes No

Does the direction of rotation of the permanent magnet dc motor depend on the polarity of the voltage applied to the motor armature? Explain.

17. In LVDAC-EMS, close the Data Table.

Torque-versus-current and speed-versus-torque characteristics of a permanent magnet dc motor operating as a motor

In this section of the exercise, you will use a battery to make the Permanent Magnet DC Motor rotate. You will vary the opposition (load) torque applied to the shaft of the Permanent Magnet DC Motor and measure the armature voltage and current, as well as the rotation speed and torque at the motor shaft.

18. On the Permanent Magnet DC Motor, make sure that switch S_1 is set to the O (off) position.

On the Four-Quadrant Dynamometer/Power Supply, set the *Operating Mode* switch to *Dynamometer*.

19. Connect the equipment as shown in Figure 46. Use the high-current (40 A) terminal of input *I1* on the Data Acquisition and Control Interface (DACI).

In the Data Acquisition and Control Settings window of LVDAC-EMS, set the *Range* of current input *I1* to *High*.

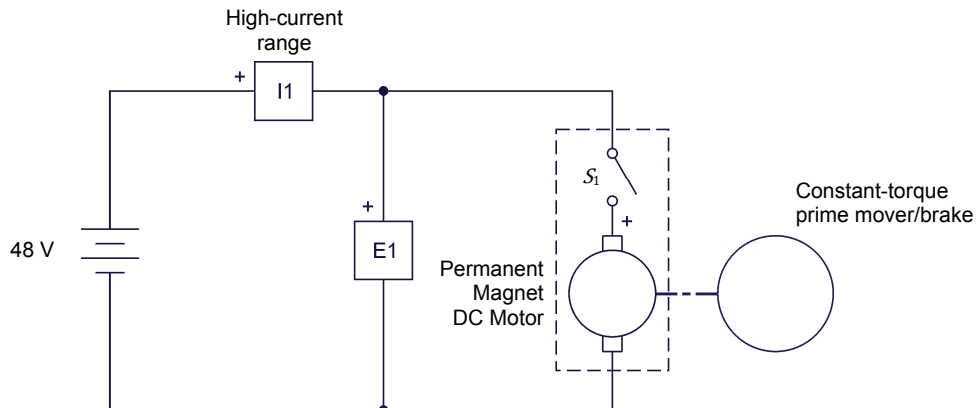

Figure 46. Setup used to plot the torque-versus-current and speed-versus-torque characteristics of a permanent magnet dc motor operating as a motor.

Clockwise rotation

20. In the Four-Quadrant Dynamometer/Power Supply window, make the following settings:

- Set the *Function* parameter to *Negative Constant-Torque Prime Mover/Brake*. This setting makes the Four-Quadrant Dynamometer/Power Supply operate as a rotating machine producing negative constant torque, i.e., constant torque in the counterclockwise direction, the constant torque setting corresponding to the *Torque* parameter. Consequently, the Four-Quadrant Dynamometer/Power Supply is set to oppose rotation of the Permanent Magnet DC Motor (i.e., apply load torque to this motor).

- Set the *Pulley Ratio* parameter to 24:12. The first and second numbers in this parameter specify the number of teeth on the pulley of the *Four-Quadrant Dynamometer/Power Supply* and the number of teeth on the pulley of the machine under test (i.e., the *Permanent Magnet DC Motor*), respectively.
 - Make sure that the *Torque Control* parameter is set to *Knob*. This allows the torque of the *Negative Constant-Torque Prime Mover/Brake* to be controlled manually.
 - Set the *Torque* parameter to -0.1 N·m (or -0.9 lbf·in) by entering this value in the field next to this parameter. This sets the torque command of the *Negative Constant-Torque Prime Mover/Brake* to -0.1 N·m (or -0.9 lbf·in).
- 21.** In the *Four-Quadrant Dynamometer/Power Supply* window, start the *Negative Constant-Torque Prime Mover/Brake* by setting the *Status* parameter to *Started* or by clicking the *Start/Stop* button.

On the *Permanent Magnet DC Motor*, set switch S_1 to the I (on) position to start the motor.

In the *Four-Quadrant Dynamometer/Power Supply* window, the *Speed* meter indicates the rotation speed of the *Permanent Magnet DC Motor*, while the *Torque* meter indicates the torque developed at the shaft of the motor. Observe that the motor rotation speed and torque are of positive polarity, indicating that the motor is rotating in the clockwise direction. Record the motor rotation speed and torque below.

Motor rotation speed = _____ r/min

Motor torque = _____ N·m or lbf·in

In the *Metering* window, meter *E1* indicates the dc voltage applied to the armature of the *Permanent Magnet DC Motor*, while meter *I1* indicates the dc current flowing in the armature of the motor. Record the armature voltage and current below.

Motor armature voltage = _____ V

Motor armature current = _____ A

- 22.** In *LVDAC-EMS*, open the *Data Table* window. Set the *Data Table* to record the motor rotation speed and torque (indicated by the *Speed* and *Torque* meters in the *Four-Quadrant Dynamometer/Power Supply* window), as well as the motor armature voltage and current (indicated by meters *E1* and *I1* in the *Metering* window).
- 23.** Make the torque produced by the *Negative Constant-Torque Prime Mover/Brake* vary from 0 to -0.6 N·m (or from 0 to about -5.0 lbf·in) in steps of 0.1 N·m (or about 1 lbf·in) by adjusting the *Torque* parameter in the *Four-Quadrant Dynamometer/Power Supply* window. For each torque setting,

record the motor armature voltage and current, as well as the motor rotation speed and torque in the [Data Table](#).

CAUTION

Make sure not to exceed the current rating of the [Permanent Magnet DC Motor](#) for extended periods of time. Perform this manipulation in less than 5 minutes.

Save the data recorded in the [Data Table](#).

Counterclockwise rotation

24. In the [Four-Quadrant Dynamometer/Power Supply](#) window, stop the [Negative Constant-Torque Prime Mover/Brake](#) by clicking the [Start/Stop](#) button or by setting the [Status](#) parameter to [Stopped](#).

On the [Permanent Magnet DC Motor](#), set switch S_1 to the O (off) position to stop the motor.

On the [Lead-Acid Battery Pack](#), reverse the battery connections to reverse the polarity of the voltage applied to the [Permanent Magnet DC Motor](#).



Reversing the power supply connections at the two terminals of a dc motor reverses the direction of rotation of the motor.

25. In the [Four-Quadrant Dynamometer/Power Supply](#) window, make the following settings:
- Set the [Function](#) parameter to [Positive Constant-Torque Prime Mover/Brake](#). This setting makes the [Four-Quadrant Dynamometer/Power Supply](#) operate as a rotating machine producing positive constant torque, i.e., constant torque in the clockwise direction, the constant torque setting corresponding to the [Torque](#) parameter. Consequently, the [Four-Quadrant Dynamometer/Power Supply](#) is once again set to oppose rotation of the [Permanent Magnet DC Motor](#) (i.e., apply load torque to this motor).
 - Set the [Pulley Ratio](#) parameter to 24:12.
 - Make sure that the [Torque Control](#) parameter is set to [Knob](#).
 - Set the [Torque](#) parameter to the minimum value (0.0 N·m or 0.0 lbf·in). This sets the torque command of the [Positive Constant-Torque Prime Mover/Brake](#) to 0.0 N·m (0.0 lbf·in).
 - Start the [Positive Constant-Torque Prime Mover/Brake](#) by clicking the [Start/Stop](#) button or by setting the [Status](#) parameter to [Started](#).
26. Start the [Permanent Magnet DC Motor](#) by setting its power switch S_1 to the I (on) position.

Make the torque produced by the *Positive Constant-Torque Prime Mover/Brake* vary from 0 to 0.6 N·m (or from 0 to about 5.0 lbf·in) in steps of 0.1 N·m (or about 1 lbf·in) by adjusting the *Torque* parameter in the *Four-Quadrant Dynamometer/Power Supply* window. For each torque setting, record the motor armature voltage and current, as well as the motor rotation speed and torque in the *Data Table*.

CAUTION

Make sure not to exceed the current rating of the *Permanent Magnet DC Motor* for extended periods of time. Perform this manipulation in less than 5 minutes.

Save the data recorded in the *Data Table*.

27. In the *Four-Quadrant Dynamometer/Power Supply* window, stop the *Positive Constant-Torque Prime Mover/Brake* by clicking the *Start/Stop* button or by setting the *Status* parameter to *Stopped*.

On the *Permanent Magnet DC Motor*, set switch S_1 to the *O* (off) position to stop the motor

28. From the results recorded in the *Data Table*, plot the curve of the motor torque as a function of the motor armature current.

According to the obtained curve, is the torque developed at the shaft of a permanent magnet dc motor operating as a motor proportional to the current flowing in the motor armature?

- Yes No

Does the direction of the torque developed at the shaft of the motor reverse when the polarity of the armature current is reversed? Explain.

29. From the results recorded in the *Data Table*, plot the curve of the motor rotation speed as a function of the motor torque.

According to the obtained curve, does the motor speed decrease as the torque developed at the motor shaft increases? Explain why.

30. Close the **Data Table**. Turn the **Four-Quadrant Dynamometer/Power Supply** off by setting the main power switch to **O** (off). Close the **LVDAC-EMS** software. Disconnect all leads and return them to their storage location.

CONCLUSION

In this exercise, you familiarized yourself with the operation of a permanent magnet dc motor used as a motor. You learned that when a dc power source is connected to the motor terminals, current flows in the wire loops of the armature and a magnetic field is produced in the wire loops. The interaction between the magnetic field produced in the armature wire loops and the magnetic field of the stator permanent magnets results in forces that produce torque that makes the rotor rotate continually in the same direction. The rotation speed of the rotor is proportional to the voltage applied to the motor armature, while the direction of rotation depends on the polarity of this voltage. For instance, when the voltage applied is of positive polarity, the rotor rotates clockwise, and vice-versa. When a load (opposition) torque is applied to the dc motor, a torque is developed at the shaft of the motor. This torque is in the same direction as the direction of rotation. When the load torque applied increases, the current flowing in the motor armature increases and, thus, the torque developed at the motor shaft increases. For a fixed armature voltage, the motor rotation speed decreases as the torque developed at the motor shaft increases.

REVIEW QUESTIONS

1. By referring to Figure 34, Figure 35, and Figure 36, briefly describe the magnetic field produced by the armature of a dc motor when the rotor rotates.

2. Refer to Figure 37. Explain why the rotor starts to rotate when it is placed within the permanent magnets at the stator of a dc motor.

3. Refer to Figure 37. Explain why the rotor rotates continually in the same direction.

4. What happens to the direction of rotation of the dc motor in Figure 37 when the dc power source connections are reversed? Explain.

5. When a fixed armature voltage is applied to a permanent magnet dc motor, what happens to the current flowing in the armature, the torque developed at the motor shaft, and the motor rotation speed as the load (opposition) torque applied to the motor increases?

Equipment Utilization Chart

The following equipment is required to perform the exercises in this manual.

Equipment		Exercise		
Model	Description	1	2	3
8131 ⁽¹⁾	Workstation	1	1	1
8213	Permanent Magnet DC Motor	1	1	1
8802	Lead-Acid Battery Pack	1	1	1
8942	Timing Belt	1	1	1
8946-2	Multimeter	1	1	1
8951-L	Connection Leads and Accessories	1	1	1
8960-C ⁽²⁾	Four-Quadrant Dynamometer/Power Supply	1	1	1
8990	Host Computer	1	1	1
9063-B ⁽³⁾	Data Acquisition and Control Interface		1	1
30004-2	24 V AC Power Supply	1	1	1
<p>⁽¹⁾ The Workstation, Model 8134-2, or the Mobile Workstation, Model 8110-2, can also be used.</p> <p>⁽²⁾ Model 8960-C consists of the Four-Quadrant Dynamometer/Power Supply, Model 8960-2, with the Standard Functions (manual control) set, Model 8968-1, and the Standard Functions (computer-based control) set, Model 8968-2.</p> <p>⁽³⁾ Model 9063-B consists of the Data Acquisition and Control Interface, Model 9063, with the Computer-Based Instrumentation function set, Model 9069-1.</p>				

Glossary of New Terms

alternating current (ac)	Alternating current is the type of current supplied to most houses and places of business. This type of current changes direction (polarity) many times each second. Examples of devices that produce ac current are alternators and ac generators.
attraction and repulsion	Like poles on magnets repel each other, while unlike poles attract each other. Therefore, when a pole on a magnet is moved toward a similar pole on another magnet, the magnets repel each other. Conversely, when a pole on a magnet is moved toward an opposite pole on another magnet, the magnets attract each other.
brushes	Stationary parts usually made of carbons which conduct current between the armature windings and the motor terminals.
commutator	An assembly of conducting segments connecting the armature windings to terminals on the motor stator, via a pair of brushes.
counter-electromotive force (CEMF)	Force that causes a voltage to be induced across the armature of a permanent magnet dc motor when the motor rotates.
direct current (dc)	This is the type of current produced by batteries and dc power sources. This type of current flows in one direction (conventional direction) only: from the positive (+) terminal of the battery or dc power source towards the negative (-) terminal.
dynamometer	A dynamometer is a device used to measure the speed of rotation and the torque produced by a motor by allowing a variable braking force (load torque or opposition torque) to be applied to the motor under test.
electromagnet	An electromagnet is a device that produces a magnetic field when an electric current flows through it. A coil of wire wound around an iron core is a common example of an electromagnet.
electromagnetic induction	Electromagnetic induction consists of the production of an electromotive force (i.e., an induced voltage) in a circuit resulting from a change in the magnetic flux cutting that circuit.
permanent magnet	A permanent magnet is a piece of iron or metal surrounded by a magnetic field. This magnetic field is constant, i.e., it persists naturally without the need of an electrical current. The magnet has a north (N) pole and a south (S) pole. These poles are situated near the ends of the magnet where the magnetic field strength is the greatest.
permanent magnet dc motor	Rotating machines that operate using direct current (i.e., they are dc powered). They can be used as either generators or motors.
prime mover	A prime mover is a device that is used to drive a rotating machine (i.e., to make the machine rotate with the prime mover).
rotor (armature)	The rotating part of a rotating machine. The rotor of a permanent magnet dc motor consists of several loops of wire and commutator segments.
stator	The fixed part of a rotating machine in which the rotor turns. The stator of a permanent magnet dc motor consists of permanent magnets aligned so that poles of opposite polarities face each other. Therefore, lines of magnetic field pass from one permanent magnet to the other through the metallic armature.

torque

The torque T produced by a rotating machine indicates the magnitude of the twisting force that the machine applies to an object in rotation. Torque can be expressed in newton-meters (N·m) or in pound-force inches (lbf·in). A motor rotates due to the torque produced by the motor when electrical power is supplied to it, while a generator rotates due to the torque applied to the generator shaft by an external force (e.g., a prime mover).

Circuit Diagram Symbols

Various symbols are used in the circuit diagrams of this manual. Each symbol is a functional representation of a particular electrical device that can be implemented using the equipment. The use of these symbols greatly simplifies the number of interconnections that need to be shown on the circuit diagram, and thus, makes it easier to understand the circuit operation.

For each symbol other than those of power sources, resistors, inductors, and capacitors, this appendix gives the name of the device which the symbol represents, as well as the equipment and the connections required to properly connect the device to a circuit. Notice that the terminals of each symbol are identified using circled letters. The same circled letters identify the corresponding terminals in the Equipment and Connections diagram. Also notice that the numbers (when present) in the Equipment and Connections diagrams correspond to terminal numbering used on the actual equipment.

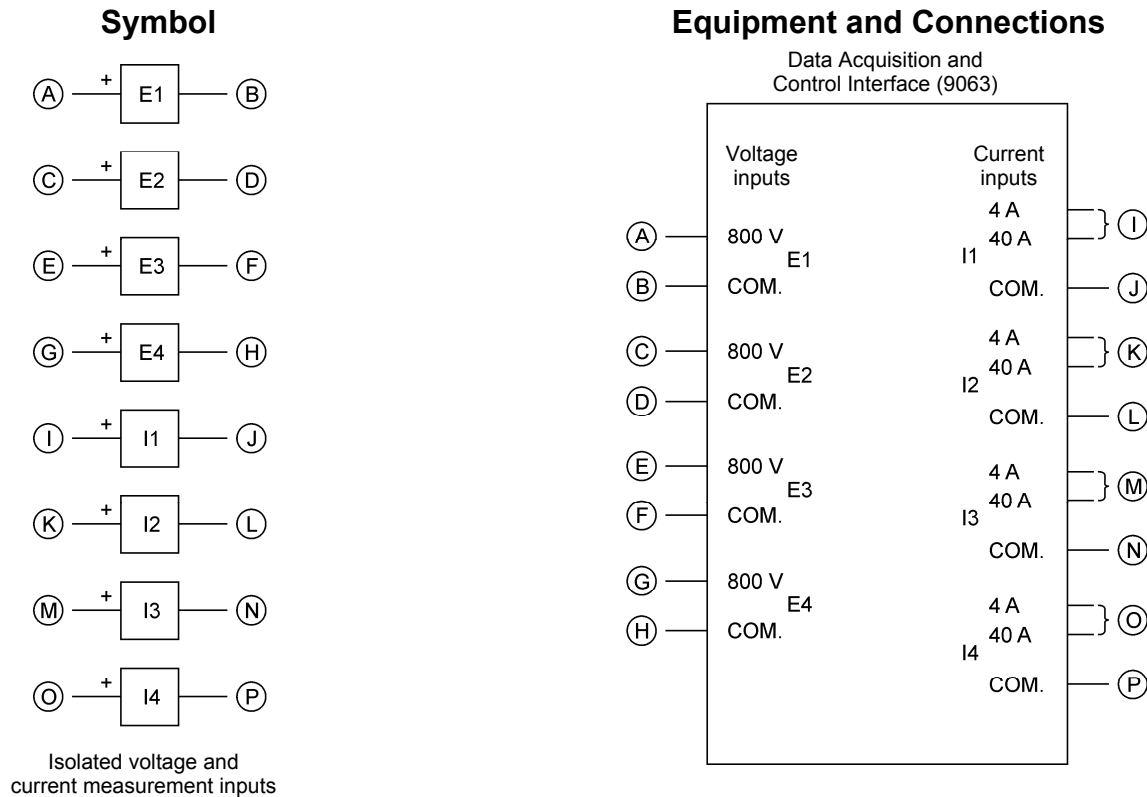

When a current at inputs I1, I2, I3, or I4 exceeds 4 A (either permanently or momentarily), use the corresponding 40 A input terminal and set the Range parameter of the corresponding input to High in the Data Acquisition and Control Settings window of LVDAC-EMS.

Symbol

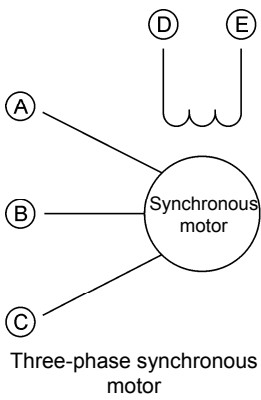
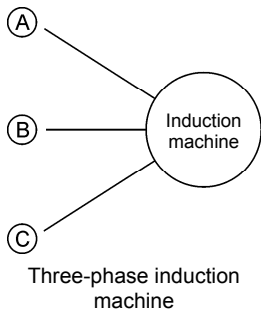
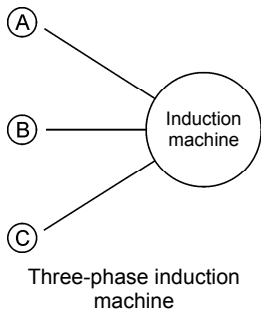

Equipment and Connections

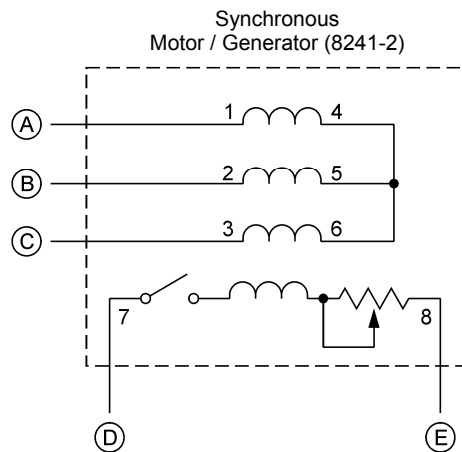
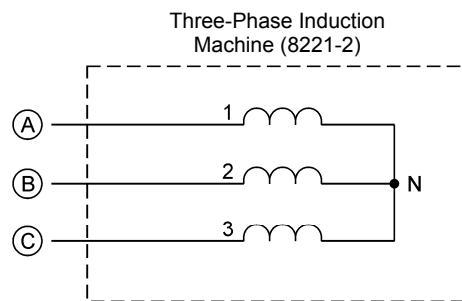
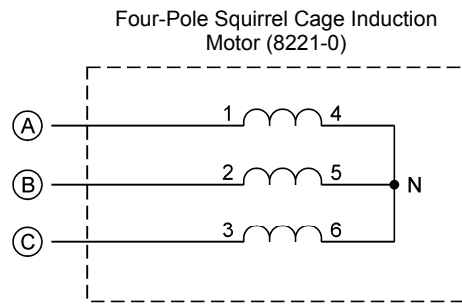

Symbol

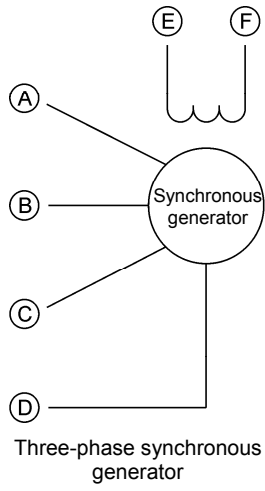

Equipment and Connections

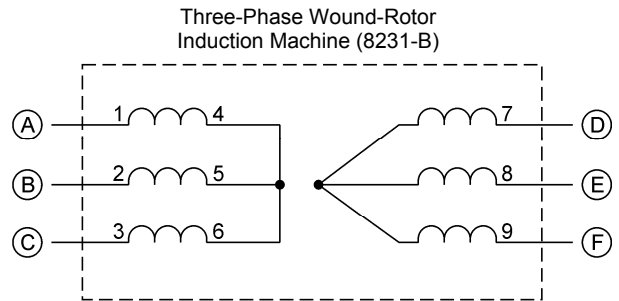
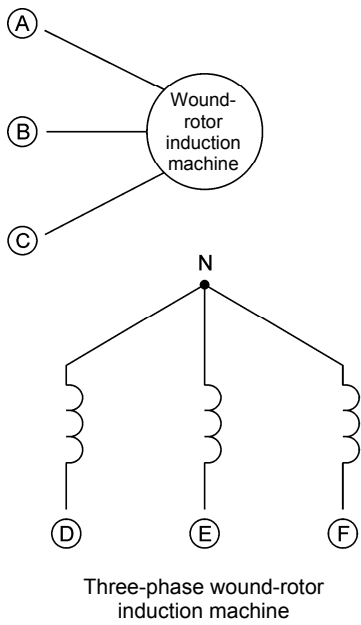
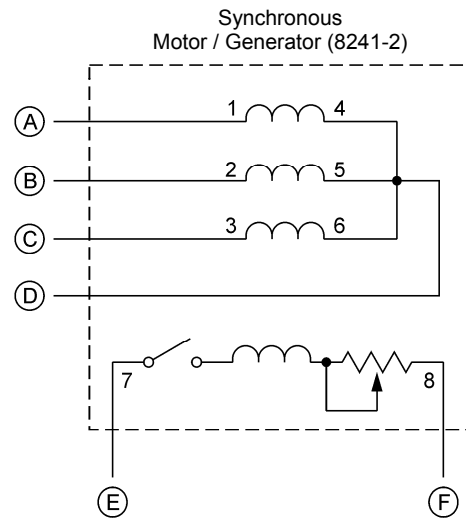

Symbol

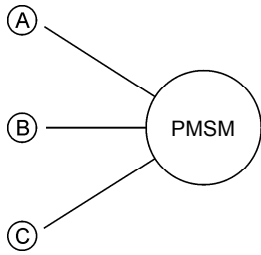

Permanent Magnet Synchronous Machine

Equipment and Connections

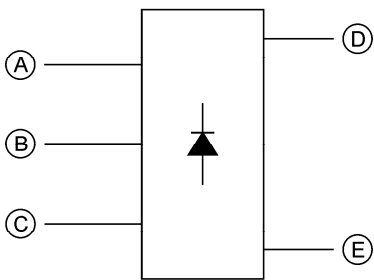
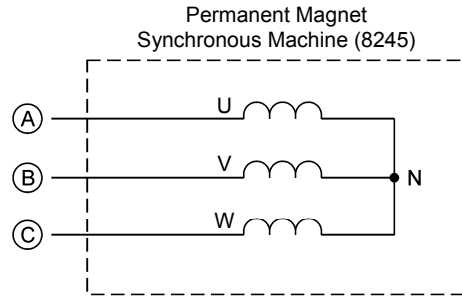

Power diode three-phase full-wave rectifier

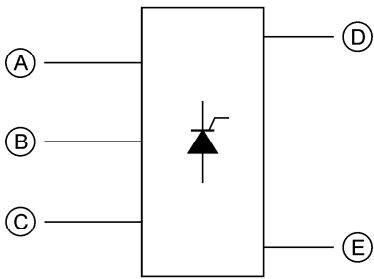
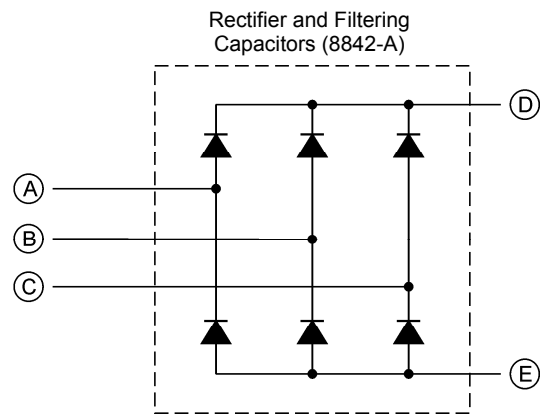

Power thyristor three-phase bridge

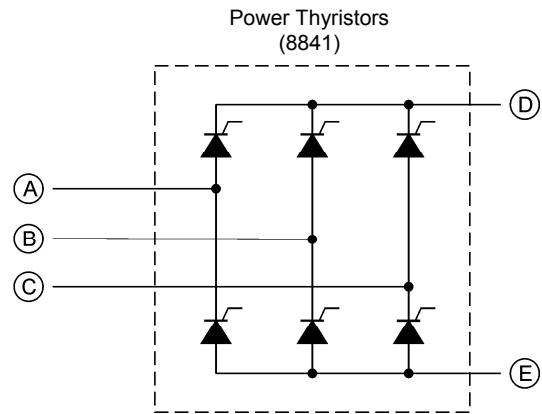

Symbol

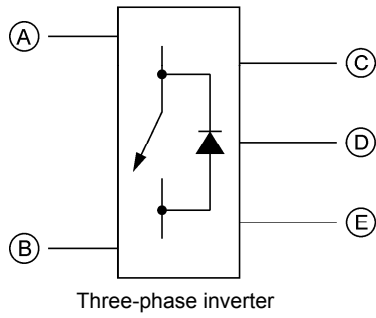

Equipment and Connections

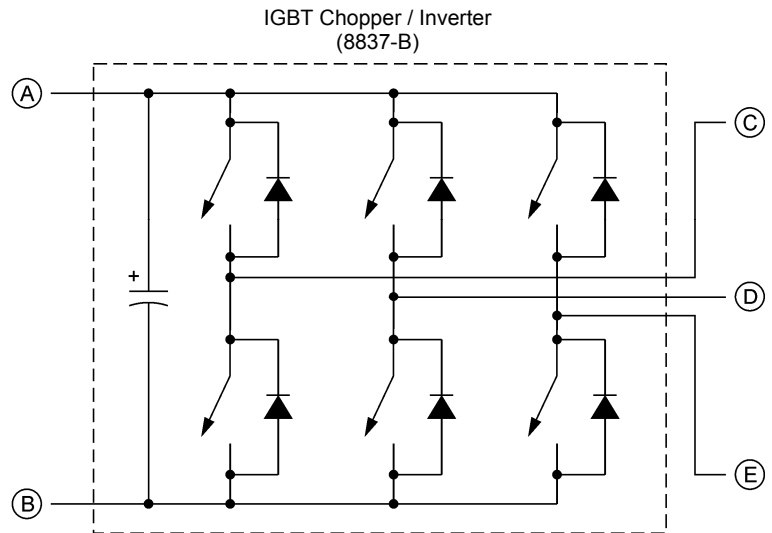

Preparation of the Lead-Acid Battery Pack

This appendix explains how to prepare (fully charge) each [Lead-Acid Battery Pack](#), Model 8802, before a laboratory period. The [Four-Quadrant Dynamometer/Power Supply](#), Model 8960, is used to charge either a single battery pack or several battery packs (connected in parallel) at a time.

Charging procedure

The charging procedure below can be performed overnight so that the equipment is ready to be used by another group of students the following day.

Perform the following steps:

1. To charge a single [Lead-Acid Battery Pack](#), start the procedure at step 2. To charge several battery packs (connected in parallel) at the same time, start the procedure at step 3.
2. Connect the positive (red) terminal of the [Lead-Acid Battery Pack](#) to the yellow [Power Supply](#) terminal of the [Four-Quadrant Dynamometer/Power Supply](#). Connect the negative (black) terminal of the [Lead-Acid Battery Pack](#) to the white [Power Supply](#) terminal of the [Four-Quadrant Dynamometer/Power Supply](#). Go to step 4.
3. Connect the [Parallel Charging Input](#) (red) terminal of each [Lead-Acid Battery Pack](#) to the yellow [Power Supply](#) terminal of the [Four-Quadrant Dynamometer/Power Supply](#). Connect the negative (black) terminal of each [Lead-Acid Battery Pack](#) to the white [Power Supply](#) terminal of the [Four-Quadrant Dynamometer/Power Supply](#). Go to the next step.
4. Make sure the main power switch of the [Four-Quadrant Dynamometer/Power Supply](#) is set to O (off), then connect the [Power Input](#) to an ac power outlet.
5. Set the [Operating Mode](#) switch of the [Four-Quadrant Dynamometer/Power Supply](#) to [Power Supply](#).
6. Turn the [Four-Quadrant Dynamometer/Power Supply](#) on by setting the main power switch to I (on).
7. On the [Four-Quadrant Dynamometer/Power Supply](#), select the [Pb-Acid Battery Float Charger](#) function using the [Function](#) button, and set the charging voltage to 55.2 V using the [Command](#) knob.

8. Start battery charging by depressing the *Start/Stop* push button. The display indicates *Started*, signifying that battery charging has begun.
9. Once battery charging is completed, stop the *Pb-Acid Battery Float Charger* by depressing the *Start/Stop* push button, then turn the *Four-Quadrant Dynamometer/Power Supply* off. Disconnect each *Lead-Acid Battery Pack* from the *Four-Quadrant Dynamometer/Power Supply*. Test each *Lead-Acid Battery Pack* for sulfation as described in the Sulfation test section of this appendix.

Sulfation test



*This test must be performed on a single *Lead-Acid Battery Pack* at a time.*

Perform the following steps:

1. Connect the positive (red) terminal of the *Lead-Acid Battery Pack* to the *Power Supply* (yellow) terminal of the *Four-Quadrant Dynamometer/Power Supply*. Connect the negative (black) terminal of the *Lead-Acid Battery Pack* to the *Power Supply* (white) terminal of the *Four-Quadrant Dynamometer/Power Supply*.
2. Make sure the main power switch of the *Four-Quadrant Dynamometer/Power Supply* is set to O (off), then connect the *Power Input* to an ac power outlet.
3. On the *Four-Quadrant Dynamometer/Power Supply*, make the settings required so that it operates as a negative current source [*Current Source (-)* function].
4. Set the current command to -4 A, then start the negative current source.
5. Observe the battery pack voltage. If the battery pack is unable to maintain its voltage above 48 V for one minute, it may be sulfated.
6. Stop the negative current source.
7. Repeat the sulfation test if you have other battery packs to test.
8. Turn the *Four-Quadrant Dynamometer/Power Supply* off.
9. Faulty battery packs can be desulfated by using a desulfator, otherwise they must be replaced.

Battery maintenance

In order to optimize the cycle life of the batteries in the [Lead-Acid Battery Pack](#) and to prevent sulfation, the battery pack should be charged as soon as possible after a discharge cycle (e.g., after completion of a laboratory exercise). The [Lead-Acid Battery Pack](#) should never be stored with the batteries discharged for an extended period of time.

Index of New Terms



The bold page number indicates the main entry. Refer to the Glossary of New Terms for definitions of new terms.

alternating-current (ac).....	35 , 38
armature.....	33 , 38, 40, 41, 42, 55, 56, 58, 59, 60, 61, 62
attraction and repulsion.....	41 , 55
brushes	5 , 33, 34, 35, 38, 55, 56, 57, 59, 60
commutator	33 , 34, 35, 38, 56, 57, 58
counter-electromotive force (CEMF).....	60
direct-current (dc).....	35
dynamometer	7
electromagnet	27 , 56, 57, 58, 59
electromagnetic induction	29 , 30
permanent magnet.....	5 , 25, 27, 30, 33, 58
permanent magnet dc motor.....	5 , 33, 34, 40, 42, 55, 60
power	2 , 7, 8, 9, 10
prime mover	7 , 8, 9, 10
rotor.....	33 , 34, 35, 40, 56, 57, 58, 59
stator	33 , 34, 41, 55
torque	2 , 3, 7, 8, 9, 10, 13, 14, 15, 17, 18, 20, 21, 22, 40, 41, 42, 60, 62, 78
work.....	1 , 2, 3

Bibliography

Wildi, Theodore, *Electrical Machines, Drives, and Power Systems*, 2nd edition, New Jersey, Prentice Hall, 1991. ISBN 0-13-251547-4.